

### Features

- **V.32 bis/V.32/V.22 bis/V.22 automodem. (14400, 12000, 9600, 7200, 4800, 2400, 1200 bps duplex)**
- **V.23 (1200/75, 1200/1200, 75, 1200 bps FSK)**
- **Bell 202 (1200/150, 1200/1200, 150, 1200 bps FSK)**
- **V.21 or Bell 103 (300/300 bps FSK)**
- **DTMF/Tones Transmit and Receive**
- **'Powersave' Standby Mode**

### Applications

- **Telephone Telemetry Systems**
- **Remote Utility Meter Reading**
- **Security Systems**
- **Industrial Control Systems**
- **Electronic Cash Terminals**
- **Pay-Phones**
- **Cable TV Set-Top Boxes**

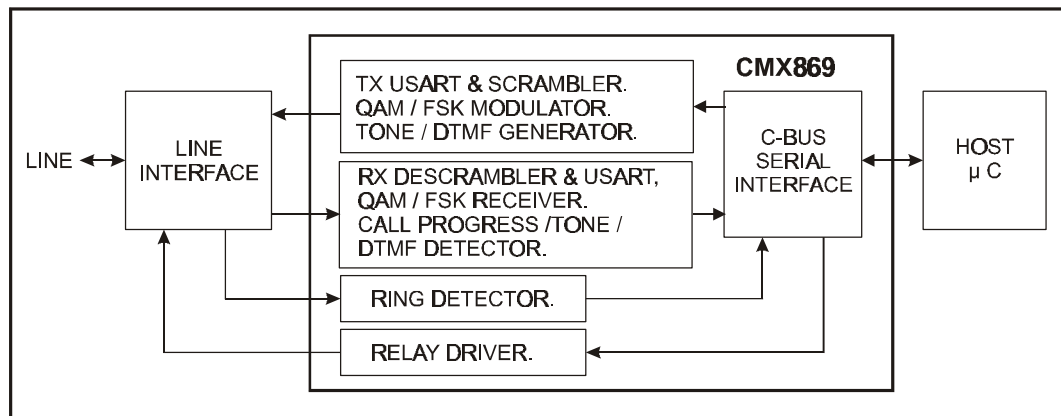

## 1. Brief Description

The CMX869 is a multi-standard modem for use in telephone based information and telemetry systems. It can transmit and detect standard DTMF and modem calling and answer signals or user-specific programmed single or dual tone signals. A general purpose Call Progress signal detector is also included.

Flexible line driver and receive hybrid circuits are integrated on chip, requiring only passive external components to build a 2 or 4-wire line interface.

The device also features a software controlled hook switch Relay Drive output and a Ring Detector circuit, which continue to function when the device is in the Powersave mode. When a line voltage reversal or ringing signal is detected, the Ring Detect Circuit can provide an interrupt which can be used to wake up the host  $\mu$ Controller.

Control of the device is via a simple high speed serial bus that operates in normal and Powersave modes, and is compatible with most types of  $\mu$ C serial interface. The data transmitted and received by the modem is also transferred over the same serial bus. On-chip programmable Tx and Rx USARTs meeting the requirements of V.14 are provided for use with asynchronous data and to allow unformatted synchronous data to be received or transmitted as 8-bit words or as a HDLC packet.

The CMX869 operates from a single 3.3V supply over a temperature range of -40°C to +85°C and is available in 24-pin TSSOP (E2), SOIC (D2) and DIL (P4) packages.

## CONTENTS

<u>Section</u>		<u>Page</u>
1.	Brief Description.....	1
2.	Block Diagram .....	3
3.	Signal List.....	4
4.	External Components.....	6
	4.1 Power Supply Connections.....	7
	4.2 Ring Detector Interface.....	8
	4.3 Line Interface.....	9
5.	General Description.....	11
	5.1 Tx USART .....	12
	5.2 FSK and QAM Modulators .....	14
	5.3 Tx Filter and Equaliser.....	14
	5.4 DTMF/Tone Generator .....	14
	5.5 Tx Level Control and Output Buffer.....	14
	5.6 Rx DTMF/Tones Detectors.....	14
	5.7 Rx Modem Filtering and Demodulation.....	15
	5.8 Rx Modem Pattern Detectors.....	15
	5.9 Rx USART .....	16
6.	C-BUS Interface and Software Description .....	18
	6.1 General Reset Command.....	20
	6.2 General Control Register .....	20
	6.3 Transmit Mode Register .....	22
	6.4 Receive Mode Register .....	25
	6.5 QAM Modem Command Register .....	27
	6.6 Tx Data Register.....	28
	6.7 Rx Data Register .....	29
	6.8 Status Register.....	30
	6.9 QAM Modem Status Register .....	33
	6.10 Programming Register.....	35
7.	Application Notes .....	38
8.	Performance Specification.....	39
	8.1 Electrical Performance.....	39
	8.1.2 Operating Limits.....	39
	8.1.3 Operating Characteristics .....	40
	8.2 Packaging.....	45

**Note:** This product is in development: Changes and additions will be made to this specification. Items marked TBD or left blank will be included in later issues.

**Information in this data sheet should not be relied upon for final product design.**

## 2. Block Diagram

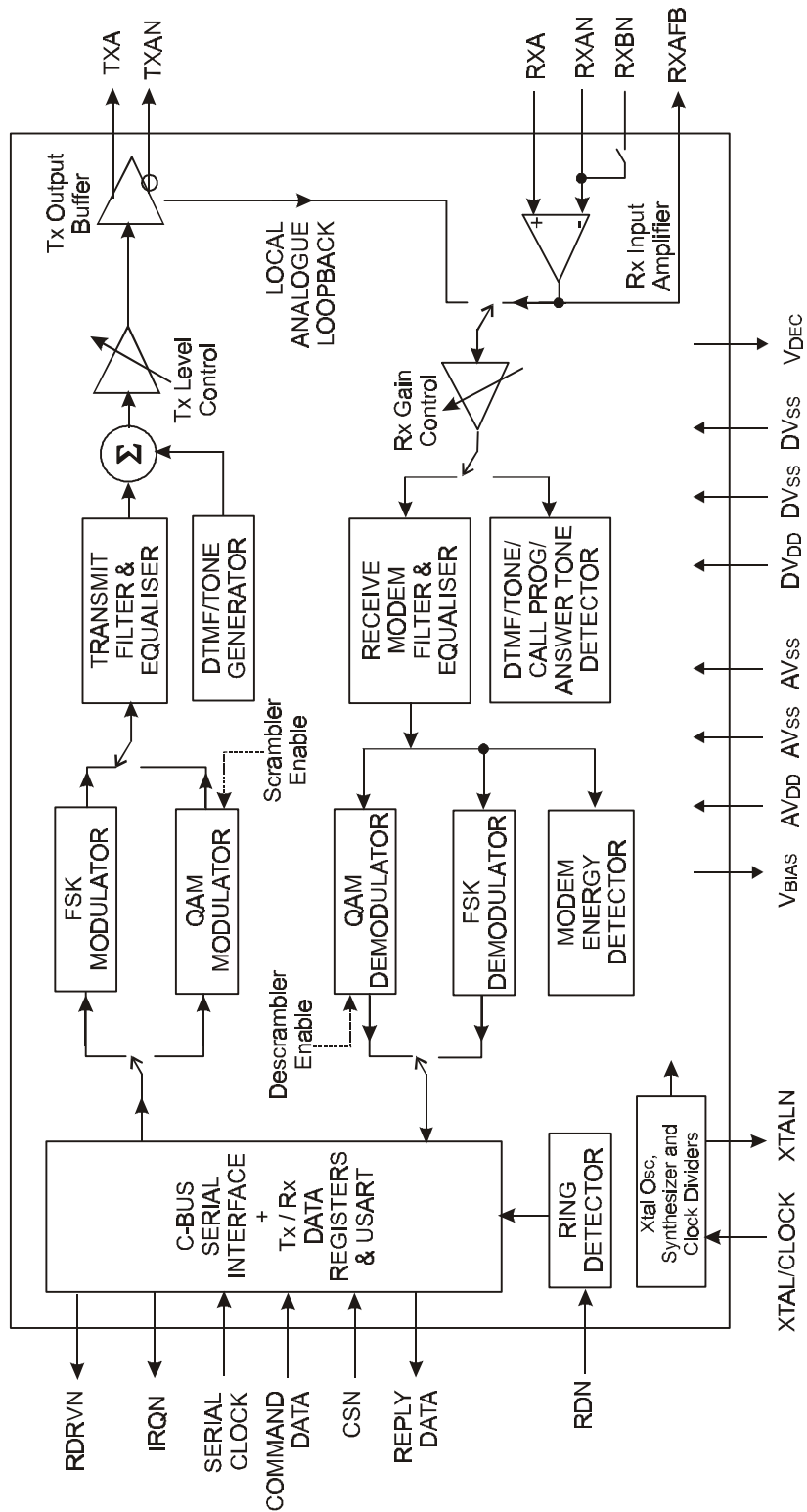

Figure 1 Block Diagram

### 3. Signal List

CMX869 D2/E2/P4	Signal		Description
Pin No.	Name	Type	
1	REPLY DATA	TS	A 3-state C-BUS serial data output to the $\mu\text{C}$ . This output is high impedance when not sending data to the $\mu\text{C}$ .
2	RDRVN	OP	Relay Drive output, low resistance pull down to $V_{SS}$ when active and medium resistance pull up to $V_{DD}$ when inactive.
4	SERIAL CLOCK	IP	The C-BUS serial clock input from the $\mu\text{C}$ .
5	COMMAND DATA	IP	The C-BUS serial data input from the $\mu\text{C}$ .
6	CSN	IP	The C-BUS chip select input from the $\mu\text{C}$ .
8	RXA	IP	The non-inverting input to the Rx Input Amplifier
9	RXBN	IP	A second, switched inverting input to the Rx Input Amplifier. Used to increase the input stage gain. If not required, leave this pin unconnected.
10	RXAN	IP	The inverting input to the Rx Input Amplifier
11	RXAFB	OP	The output of the Rx Input Amplifier.
13	$V_{BIAS}$	OP	Internally generated bias voltage of approximately $AV_{DD}/2$ , except when the device is in 'Powersave' mode when $V_{BIAS}$ will discharge to $AV_{SS}$ . Must be decoupled to $AV_{SS}$ by a capacitor mounted close to the device pins.
14	TXAN	OP	The inverted output of the Tx Output Buffer.
15	TXA	OP	The non-inverted output of the Tx Output Buffer.
17	RDN	IP	Schmitt trigger input to the (inverting) Ring signal detector. Connect to $DV_{DD}$ if Ring Detector is not used.
18	-	NC	Reserved for future use. Do not connect to this pin.
20	$V_{DEC}$	PWR/ OP	Internally generated 2.5V supply voltage. Must be decoupled to $DV_{SS}$ by capacitors mounted close to the device pins. No other connections allowed.
21	XTAL/CLOCK	IP	The input to the oscillator inverter from the Xtal circuit or external clock source.
22	XTALN	OP	The output of the on-chip Xtal oscillator inverter.
24	IRQN	OP	A 'wire-ORable' output for connection to a $\mu\text{C}$ Interrupt Request input. This output is pulled down to $DV_{SS}$ when active and is high impedance when inactive. An external pullup resistor is required ie R1 of Figure 2

**Signal list (cont.)**

CMX869 E2	Signal		Description
Pin No.	Name	Type	
3, 19	DV <sub>SS</sub>	PWR	The negative supply rail (ground) for the digital on-chip circuits.
7, 16	AV <sub>SS</sub>	PWR	The negative supply rail (ground) for the analogue on-chip circuits.
12	AV <sub>DD</sub>	PWR	The positive supply rail for the analogue on-chip circuits. Levels and thresholds within the device are proportional to this voltage.
23	DV <sub>DD</sub>	PWR	The positive supply rail for the digital on-chip circuits.

**Notes:**

IP	=	Input
OP	=	Output
TS	=	3-state Output
PWR	=	Power
NC	=	No Connection

### 4. External Components

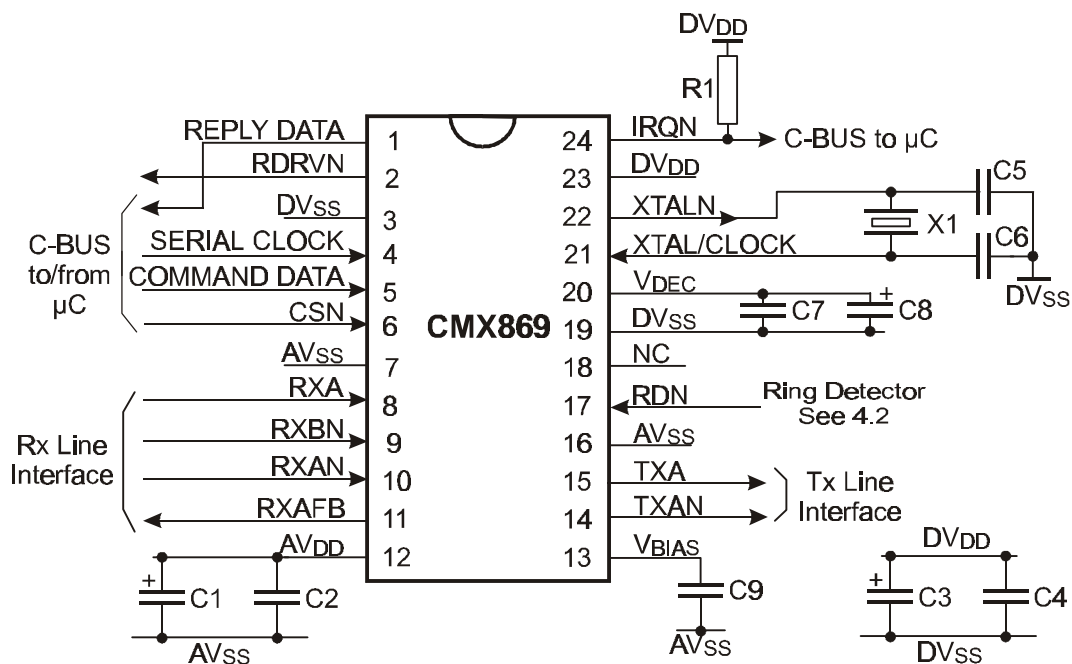

R1	100kΩ	C2, C4, C7, C9	100nF
X1	6.144MHz	C5, C6	22pF
C1, C3, C8	10uF		

Resistors ±5%, capacitors ±20% unless otherwise stated.

**Figure 2a Recommended External Components for a Typical Application**

This device is capable of detecting and decoding small amplitude signals. To achieve this DV<sub>DD</sub>, AV<sub>DD</sub> and V<sub>BIAS</sub> should be decoupled and the receive path protected from extraneous in-band signals. It is recommended that the printed circuit board is laid out with both AV<sub>SS</sub> and DV<sub>SS</sub> ground planes in the CMX869 area, as shown in Figure 2b, with provision to make a link between them close to the CMX869. To provide a low impedance connection to ground, the decoupling capacitors (C1 – C4, C7, C8) must be mounted as close to the CMX869 as possible and connected directly to their respective ground plane. This will be achieved more easily by using surface mounted capacitors.

V<sub>BIAS</sub> is used as an internal reference for detecting and generating the various analogue signals. It must be carefully decoupled, to ensure its integrity. If V<sub>BIAS</sub> needs to be used (other than as shown in figures 4a or 4b) to set external analogue levels, it must be buffered with a high input impedance buffer.

The DV<sub>SS</sub> connections to the Xtal oscillator capacitors C5 and C6 should also be of low impedance and preferably be part of the DV<sub>SS</sub> ground plane to ensure reliable start up of the oscillator.

### 4.1 Power Supply Connections

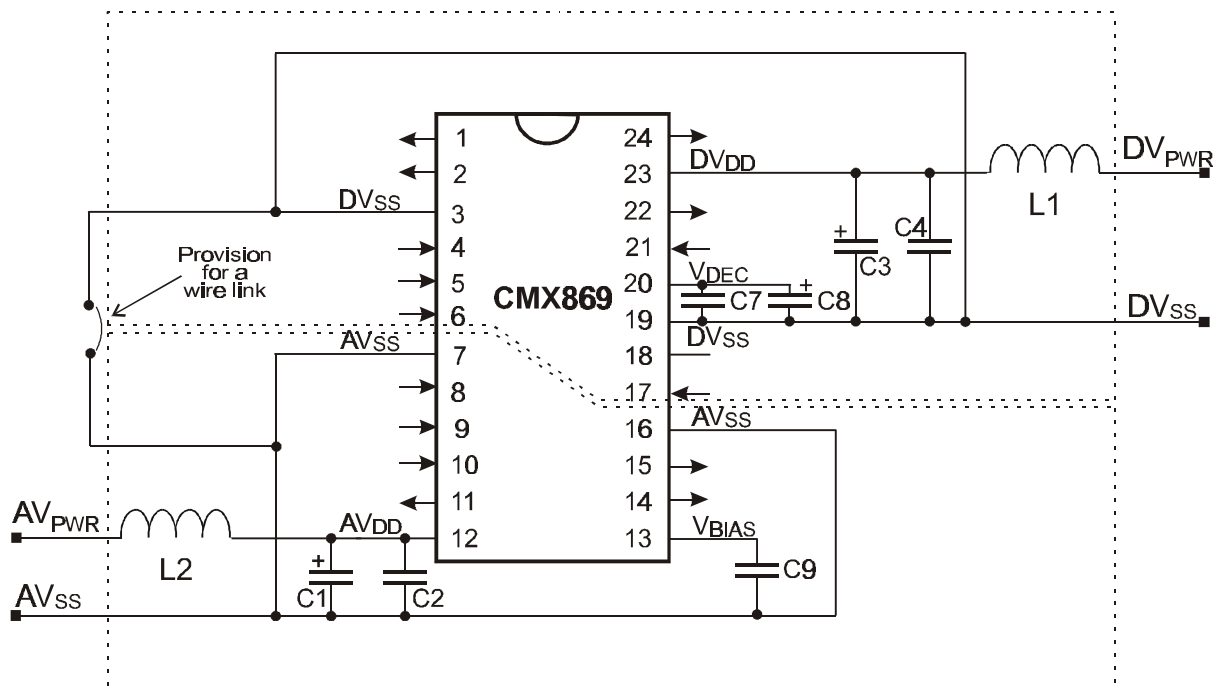

ANALOGUE		DIGITAL	
C2, C9	100nF	C4, C7	100nF
C1	10uF	C3, C8	10uF
L2	100nH (optional)	L1	100nH (optional)

**Figure 2b Recommended Power Supply Connections and De-coupling**

The inductors L1 and L2 can be omitted but this may degrade system performance.

Ensure that the length of the tracks between capacitors C2, C4, C7 and C9 and their corresponding CMX869 device pins (pins 12, 23, 20 and 13) are kept as short as possible.

### 4.2 Ring Detector Interface

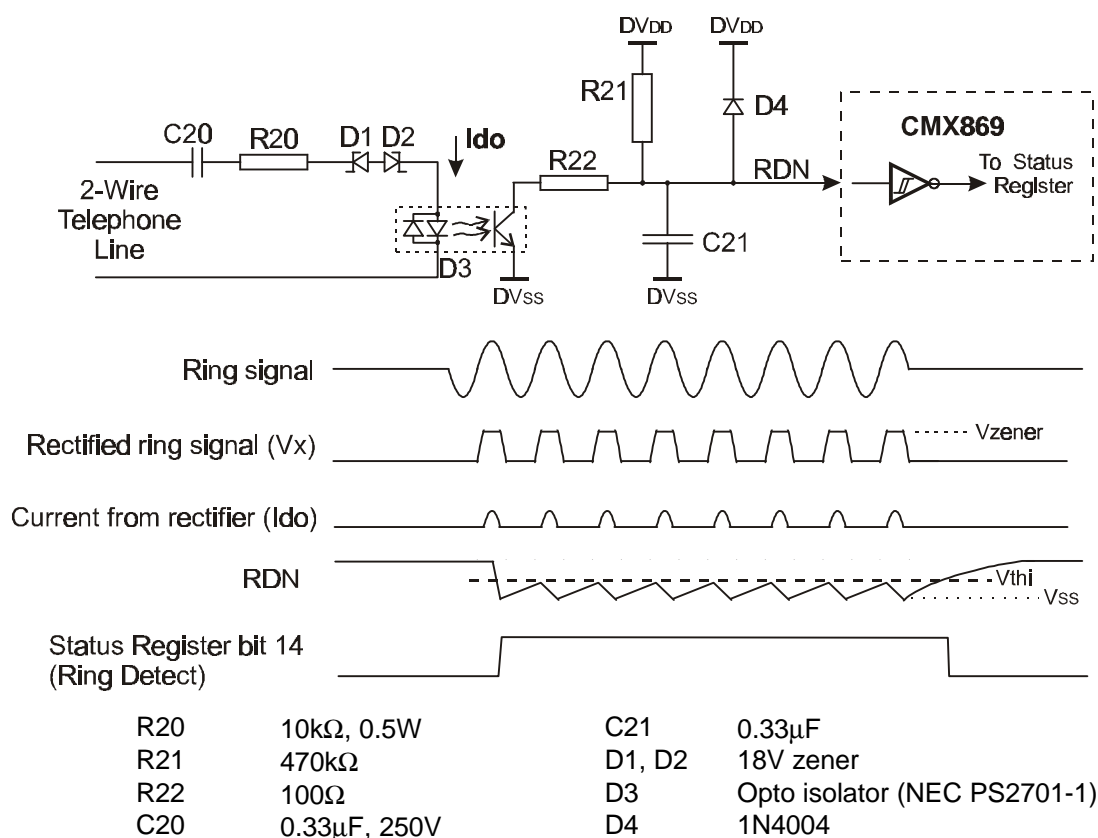

Resistors ±5%, capacitors ±20%. Circuit and all component types and values **TBD**.

**Figure 3 Ring Signal Detector Interface Circuit**

Figure 3 shows how the CMX869 may be used to detect the large amplitude Ringing signal voltage present on the 2-wire line at the start of an incoming telephone call. The ring signal is usually applied at the subscriber's exchange as an ac voltage inserted in series with one of the telephone wires and will pass through C20, R20, D1 and D2, and appear at the terminals of D3. When the signal reaches the zeners' (D1, D2) turn-on voltage, current will flow into the opto-isolator diode, turning on its output transistor and discharging capacitor C21. Resistor R22 limits the current drawn by the opto-isolator output to ~30mA peak (**TBD**). Whilst the ring tone is active and exceeds the zener voltage, the RDN node will be taken low and the output of the Schmitt trigger will go high. The state of bit 14 (Ring Detect) of the Status Register directly corresponds to the state of the Ring Detect Schmitt trigger output. If the corresponding interrupt mask bit is set to 1, a C-BUS interrupt will be initiated (see the Status Register description in section 6.8).

The minimum amplitude ringing signal that is certain to be detected is:  $V_{zener} + 2xV_{diode} + 2V$  (**TBD**).



### 4.3 Line Interface

A line interface circuit is needed to provide dc isolation and to terminate the line. The CMX869 is connected to the line when the line relay is closed. The relay may be driven from the RDRVN output, as shown in figure 4a. Control of the output level of the RDRVN pin is described in section 6.2. The diagrams of Figure 4a and Figure 4b are functional representations only and should not be used in product designs. A reference design will be available separately.

#### 2-Wire Line Interface

Figure 4a shows a simplified interface for use with a 600Ω 2-wire line. The line termination impedance is provided by the transformer, R13 and C10, high frequency noise is attenuated by C10 and C11, while R11 and R12 set the receive signal level into the modem. For clarity the 2-wire line protection circuits have not been shown.

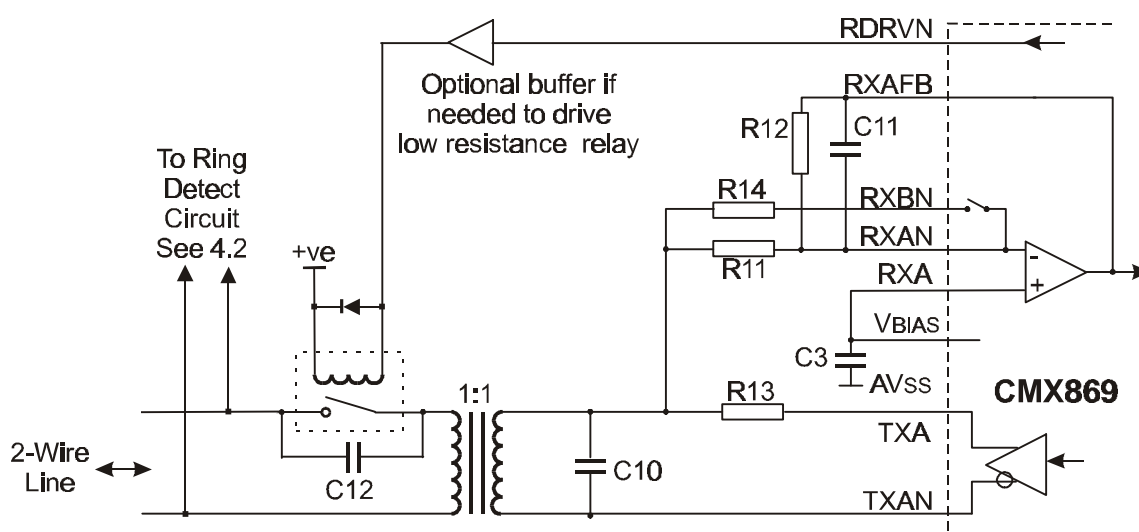

R11	130kΩ (see text)	C3	See Figure 2
R12	100kΩ	C10	33nF
R13	600Ω	C11	100pF
R14	15kΩ (see text)	C12	100nF, 250V (see text)

Resistors ±5%, capacitors ±20%

**Figure 4a 2-Wire Line Interface Circuit**

The transmit line signal level is determined by the voltage swing between the TXA and TXAN pins, less 6dB due to the line termination resistor R13, and less the loss in the line coupling transformer. Allowing for 1dB loss in the transformer, with the Tx Mode Register set for a Tx Level Control gain of 0dB the nominal transmit line levels will be:

	<b>VDD = 3.3V</b>
QAM and FSK Tx modes (no guard tone)	-7.5 dBm
Single tone transmit mode	-7.5 dBm
DTMF transmit mode	-3.5 and -5.5 dBm

For a line impedance of 600Ω, 0dBm = 775mVrms. See also section 8.1.3

In the receive direction, the signal detection thresholds within the CMX869 are proportional to  $AV_{DD}$  and are affected by the Rx Gain Control gain setting in the Rx Mode Register. The signal level into the CMX869 is affected by the line coupling transformer loss and the values of R11 and R12 of Figure 4a.

The value of R11 should be chosen so that the received signal level at the RXAFB pin is 3.6dB lower than that on the 2-wire line. For example if the transformer loss is 1dB then R11 should be 130k $\Omega$ . The value of R14 (15k $\Omega$ ) is chosen to apply approximately 20dB of extra gain, when required by Type 1 Caller Line Identification.

For best Rx performance, it is recommended that the transformer coupling arrangement should provide at least 7dB trans-hybrid loss.

The RXBN input can be selected by setting bit 14 of the General Control Register to 1, which internally connects RXBN to RXAN. With the components shown in Figures 4a and 4b, this will add approximately 20dB to the Rx gain, by connecting R14 in parallel with R11. This facilitates detection of certain signals whilst on-hook, such as may be required for Type 1 Caller Line Identification reception. For the 2-wire line interface shown in Figure 4a, capacitor C12 is required to provide an AC path through to the device when the relay is open. If this facility is not required, R14 and C12 can be omitted.

**4-Wire Line Interface**

Figure 4b shows a simplified interface for use with a 600 $\Omega$  4-wire line. The line terminations are provided by R10 and R13, high frequency noise is attenuated by C11 while R11 and R12 set the receive signal level into the modem. Transmit and receive line level settings and the values of R11 and R14 are as for the 2-wire circuit.

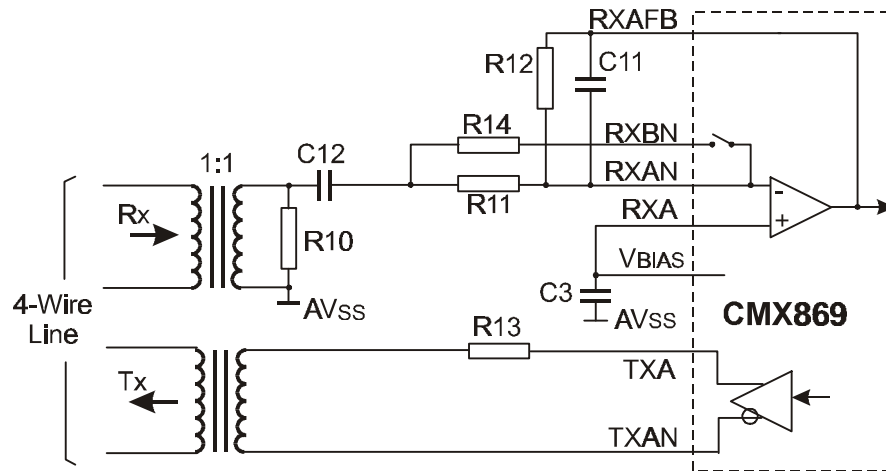

R10, 13	600 $\Omega$	C3	See Figure 2
R11	130k $\Omega$ (see text)	C11	100pF
R12	100k $\Omega$	C12	33nF
R14	15k $\Omega$ (see text)		

Resistors  $\pm 5\%$ , capacitors  $\pm 20\%$

**Figure 4b 4-Wire Line Interface Circuit**

## 5. General Description

The CMX869 can operate as a full duplex QAM (Quadrature Amplitude Modulation) or DPSK (Differential Phase Shift Keying) automodem, using the following modulation schemes:

- V.32bis
- V.32
- V.22bis
- V.22

with data rates of 14400, 12000, 9600, 7200, 4800, 2400 or 1200bps.

**Note:** reference to QAM elsewhere in the datasheet implies QAM or DPSK, according to selected operating mode.

It can also be set to operate in the following low speed modem modes:

- V.21 or Bell 103. 300/300bps duplex FSK (Frequency Shift Keying).
- V.23 modem. 1200 or 75 bps FSK.
- Bell 202 modem. 1200 or 150 bps FSK.

The transmit circuits can also be set to any one of the following:

- DTMF transmit.
- Single tone transmit (from a range of modem calling, answer and other tone frequencies)
- User programmed tone or tone pair transmit (programmable frequencies and levels)
- Disabled.

And the receive circuits can be set to:

- DTMF detect.
- 2100Hz and 2225Hz answer tone detect.
- Call progress signal detect.
- User programmed tone or tone pair detect.
- Disabled.

The Ring Detect, Tone Decoder and FSK modem circuits can be configured to facilitate Type 1 (On-Hook) Caller Identification. This facility is the subject of separate application notes.

When not in use, the CMX869 may be set into a Powersave mode, which disables all circuitry except for the on-chip regulator, the C-BUS interface and the Ring Detector.

### 5.1 Tx USART

A flexible Tx USART is provided for all modem modes, meeting the requirements of V.14 for the QAM (V.32bis/V.32/V.22bis/V.22) modem modes.

It can be programmed to transmit continuous patterns, Start-Stop characters, Synchronous unformatted data or HDLC formatted packets.

In HDLC, Synchronous Data and Start-Stop modes the data to be transmitted is written by the  $\mu$ C into the C-BUS Tx Data Register. The Tx Data Register can be set to operate in 8 or 16-bit mode by setting the Tx Mode Register b6 appropriately.

In 16-bit (2 character) mode data written to the Tx Data Register at C-BUS address \$E3 will be treated as two octets, b15-8 which will be transmitted first and b7-0 which will be transmitted second. If there is a need to transmit a single octet when the Tx Data Register has been set to 16-bit mode this can be achieved by writing the 8-bit data to C-BUS address \$E4 instead of \$E3.

If the Tx Data Register has been set to operate in 8-bit (1 character) mode, data should normally be written to C-BUS address \$E3, address \$E4 being used to provide for Start-Stop transmit data overspeed as described later.

If Synchronous Data mode has been selected the 8 data bits of each octet in the Tx Data Buffer are transmitted serially, the lsb being sent first.

In Start-Stop mode an asynchronous character is transmitted for each octet in the Tx Data Register. Each character consists of a single Start bit followed by 5, 6, 7 or 8 data bits from the Tx Data Buffer - lsb first - followed by an optional Parity bit then - normally - one or two Stop bits. The Start, Parity and Stop bits are generated by the USART as determined by the Tx Mode Register settings and are not taken from the Tx Data Register.

In HDLC mode the octets from the Tx Data Register are packetized into a HDLC Frame consisting of a Flag byte (01111110 binary) followed by the data octets themselves, each transmitted lsb first, followed by a 16-bit Frame Check Sequence followed by another Flag byte to mark the end of the Frame. To prevent the data or FCS aliasing a Flag byte a binary 0 is inserted in the transmit bit stream after every 5 consecutive 1s in the data and FCS fields. The Flag bytes and FCS are automatically generated by the CMX869.

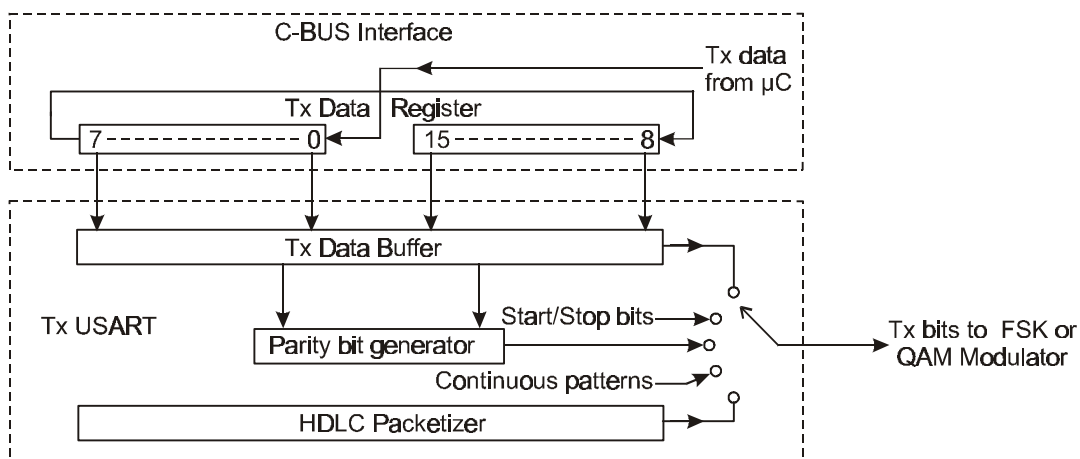

Figure 5a Tx USART (in 16 Bit Mode)

Tx Line Signal: 

Start	B0	B1	-----	B7	Par'y	Stop
-------	----	----	-------	----	-------	------

**Figure 5b Tx USART Output: Start-Stop mode, 8 Data Bits + Parity**

Flag	-----	Data Octets	-----	FCS	Flag
------	-------	-------------	-------	-----	------

**Figure 5c HDLC Frame Structure**

Every time the contents of the C-BUS Tx Data Register have been transferred to the Tx Data Buffer the Tx Data Ready flag bit of the Status Register is set to 1 to indicate that new data should be loaded into the C-BUS Tx Data Register. This flag bit will be cleared to 0 when a new value is loaded into the Tx Data Register.

If a new value is not loaded into the Tx Data Register in time for the next Tx Data Register to Tx Data Buffer transfer then the Status Register Tx Data Underflow bit will be set to 1. This bit will be cleared to 0 when a new value is loaded into the Tx Data Register.

In Synchronous Data mode the last transmitted byte will be re-transmitted if there is no new data in the Transmit Data Register. In Start-Stop mode a continuous Stop signal (1) will be transmitted.

In HDLC mode the Status Register Tx Data Underflow bit becoming set to 1 is taken by the CMX869 to indicate the end of data for a frame. The CMX869 will then transmit the FCS followed by at least one Flag byte. Flag bytes will continue to be transmitted until a new Frame is started by loading a new value into the Transmit Data Register.

In all modes the transmitted bit and baud rates are the nominal rates for the selected modem type, with an accuracy determined by the XTAL frequency accuracy, however for QAM modes V.14 requires that Start-Stop characters can be transmitted at up to 1% overspeed (basic signalling rate range) or 2.3% overspeed (extended signalling rate range) by deleting a Stop bit from no more than one out of every 8 (basic range) or 4 (extended range) consecutive transmitted characters.

To accommodate this V.14 requirement the CMX869 allows the controlling  $\mu$ C to reduce the number of transmitted Stop bits by one for selected characters in QAM Start-Stop modes. To do this, 2 character mode must be disabled in the Tx Mode Register (b6 set to 0). Characters written to the C-BUS Tx Data Register at address \$E3 will then be transmitted with the programmed number of Stop bits, but a character written to \$E4 will be transmitted with one less Stop bit than the number programmed in the Tx Mode Register.

In FSK Start-Stop modes, if the Tx Mode Register is set for 1 character mode (b6 = 0) data written to \$E4 will be transmitted with a 12.5% reduction in the length of the Stop bit at the end of that character. In all 8 bit Synchronous Data modes data, written to \$E4 will be treated as though it had been written to \$E3. The behaviour is not defined for 16 bit data mode.

The underspeed transmission requirement of V.14 is automatically met by the CMX869 as in Start-Stop mode it will insert extra Stop bit(s) if it has to wait for new data to be loaded into the C-BUS Tx Data Register.

The QAM (V.32bis/V.32/V.22bis/V.22) modulators include compatible data scrambler functions that are automatically enabled as required.

## 5.2 FSK and QAM Modulators

Serial data from the USART is fed to the FSK modulator if V.21, V.23, Bell 103 or Bell 202 mode has been selected, or to the QAM modulator for V.22bis, V.22, V.32bis and V.32 modes.

The FSK modulator generates one of two frequencies according to the transmit mode and the value of current transmit data bit.

In V.22bis and V.22 modes, QAM modulation is applied to a carrier of 1200Hz (Low Band, Calling modem) or 2400Hz (High Band, Answering modem).

In V.32bis and V.32 modes, QAM modulation is applied to a carrier of 1800Hz, using Trellis encoding for most bit rates.

## 5.3 Tx Filter and Equaliser

The FSK or QAM modulator output signal is fed through the Transmit Filter and Equaliser block which limits the out-of-band signal energy to acceptable limits. The appropriate equalisation for the particular operating mode is determined and selected automatically, by the device.

## 5.4 DTMF/Tone Generator

In DTMF/Tones mode this block generates DTMF signals or single or dual frequency tones. In V.22 bis modem mode it is used to generate the optional 550Hz or 1800Hz guard tone.

## 5.5 Tx Level Control and Output Buffer

The outputs (if present) of the Transmit Filter and DTMF/Tone Generator are summed then passed through the programmable Tx Level Control and Tx Output Buffer to the pins TXA and TXAN. The Tx Output Buffer has symmetrical outputs to provide sufficient line voltage swing and to reduce harmonic distortion of the signal.

In normal (non loopback) mode, the output from the Rx Input Amplifier is fed to the Rx Gain Control block. This provides the ability to attenuate the received signal by up to 10.5dB, depending on the value programmed into the Receive Mode Register. The output from the Rx Gain Control block is routed either to the Modem functions or to the Tone Detectors.

## 5.6 Rx DTMF/Tones Detectors

In Rx Tones Detect mode the received signal, after passing through the Rx Gain Control block, is fed to the DTMF / Tones / Call Progress / Answer Tone Detector. The user may select any of four separate detectors:

The DTMF Detector detects standard DTMF signals and identifies the transmitted character in the Status Register. A valid DTMF signal will set bit 5 of the Status Register to 1 for as long as the signal is detected.

The Programmable Tone Pair Detector includes two separate tone detectors (see Figure 10). The first detector will set bit 6 of the Status Register for as long as a valid signal is detected, the second detector sets bit 7, and bit 10 of the Status Register will be set when both tones are detected.

The Call Progress Detector measures the amplitude of the signal at the output of a 275Hz - 665Hz bandpass filter and sets bit 10 of the Status Register to 1 when the signal level exceeds the measurement threshold. The response of the Call Progress filter, including the effect of external components of figures 4a and 4b, is shown in Figure 6.

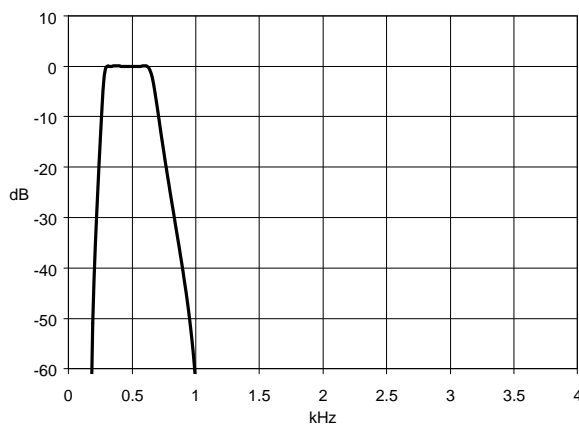

**Figure 6 Response of Call Progress Filter**

The Answer Tone Detector measures both amplitude and frequency of the received signal and sets bit 6 or bit 7 of the Status Register when a valid 2225Hz or 2100Hz signal is received.

## 5.7 Rx Modem Filtering and Demodulation

When the receive part of the CMX869 is operating as a modem, the received signal is fed through a bandpass filter to attenuate unwanted signals. The characteristics of the filter are determined by the chosen receive modem type and frequency band.

The output of the filter is fed to the appropriate FSK or QAM demodulator depending on the selected modem type.

In FSK modem modes the signal level at the output of the Filter is also measured, compared to a threshold value, and the result controls bit 10 of the Status Register.

In QAM modem modes, a V.32 bis/V.32 echo canceller is included, which will work with a round trip delay of up to 1.25seconds.

## 5.8 Rx Modem Pattern Detectors

In FSK modem modes the received bit stream is monitored for continuous 1's, for continuous 0's, and for continuous alternating 1's and 0's. Bit 7, 8 or 9 of the Status Register will be set to 1 whenever 32 bits of the appropriate pattern has been received and will then remain at 1 for 12 bit times after the end of the detected pattern unless the receive operating mode is changed, in which case the pattern detectors are reset within 2 msec.

In QAM modem modes a V.14 'Break' signal detector is implemented in Start-Stop mode by monitoring the received data and setting bit 8 of the Status Register when  $2N + 4$  consecutive 0's have been received, N being the total number of bits per character including the Start, Stop and any Parity bits. The demodulated data is passed through a de-scrambler according to the requirements of the receiver operating mode. This function is enabled automatically, as required.

### 5.9 Rx USART

A flexible Rx USART is provided for all modem modes, meeting the requirements of V.14 for QAM (V.22, V.22 bis, V.32 and V.32 bis) modem modes. Depending on the setting of the Rx Mode Register it will treat the received data bit stream as Synchronous data, as Start-Stop characters or as HDLC Frames.

#### Synchronous mode

In Synchronous mode the received data bits are all fed into an internal Rx Data Buffer which is copied into the C-BUS Rx Data Register after every 8 or 16 bits, depending on the setting of the Rx Mode Register '2 character mode' bit, b6.

#### Start-Stop (asynchronous) mode

In Start-Stop mode the USART Control logic looks for the start of each character, then feeds only the required number of data bits (not parity) into an internal Rx Data Buffer. If the parity bit is used, both parity and the presence of a Stop bit are checked. Depending on the setting of b6 of the Rx Mode Register, the data bits from 1 or 2 received characters are placed into the C-BUS Rx Data Register. If parity has been enabled the C-BUS Status Register 'Even Parity' bit(s) are set or cleared according to the received parity.

If the Stop bit is missing at the end of a character (a '0' received instead of a '1') the received character will still be placed into the C-BUS Rx Data Register, but unless allowed by the V.14 overspeed option described below, the Status Register Rx Framing Error bit will be set to '1' and the USART will re-synchronise onto the next '1' - '0' (Stop - Start) transition.

If 2-character mode has been selected by setting b6 of the Rx Mode Register received characters will normally be transferred to the C-BUS Rx Data Register two at a time and the Status Register b1 set to 1. However, the USART includes a time-out function so that if a message contains an odd number of characters the final character will be transferred to the Rx Data Register and b1 of the Status Register will be cleared to indicate that the controlling  $\mu$ C should read only 8 bits from the C-BUS Rx Data Register.

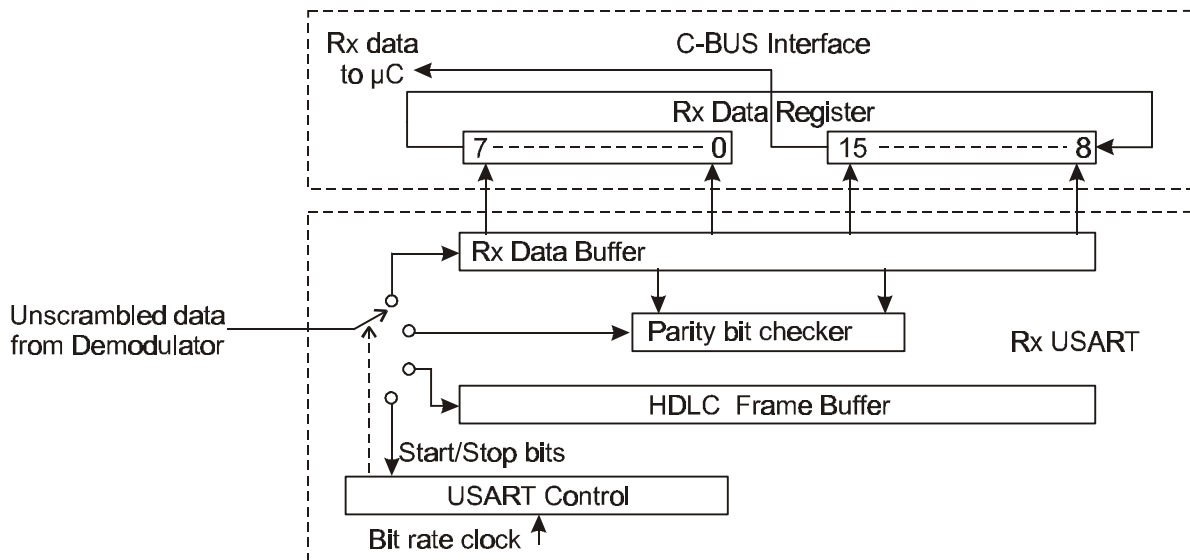

Figure 7 Rx USART (in 16 Bit Mode)



**HDLC mode**

In HDLC mode the CMX869 recognises the start and end of an HDLC Frame by monitoring the received bit stream for the presence of the flag byte (01111110 binary). The received data and FCS octets within the Frame are then passed to the C-BUS Rx Data Register (one or two octets at a time depending on the setting of the Rx Mode Register '2-character' bit, b6) after removal of any 'stuffed' 0's. A 16-bit Frame Check Sequence is calculated from the received data octets and compared to the received FCS at the end of the Frame, bit 4 of the Status Register being set to 1 if the two FCSs do not match.

If 2-character mode has been selected by setting b6 of the Rx Mode Register to 1, received data and FCS octets will normally be transferred to the C-BUS Rx Data Register two at a time, and Status Register bit 1 will be set to 1. However if the message contains an odd number of octets, Status Register bit 1 will be cleared to 0 when the final octet is transferred to the Rx Data Register, to indicate that the controlling  $\mu$ C should read only 8 bits from the C-BUS Rx Data Register.

**Status Register Rx Data Ready and Rx Data Overflow bits**

Whenever a new character or characters is copied into the C-BUS Rx Data Register, the Rx Data Ready flag bit b6 of the Status Register is set to '1' to prompt the  $\mu$ C to read the new data.

If the  $\mu$ C has not read the previous data from the Rx Data Register by the time that the CMX869 places fresh data into it, the Rx Data Overflow flag bit, b5 of the Status Register, will be set to 1.

The Rx Data Ready flag and Rx Data Overflow bits are cleared to 0 when the Rx Data Register is read by the  $\mu$ C.

**Overspeed**

For QAM (V.22, V.22 bis, V.32 and V.32 bis) Start-Stop modes, V.14 requires that the receive USART be able to cope with missing Stop bits; up to 1 missing Stop bit in every 8 consecutive received characters being allowed for the +1% overspeed (basic signalling rate) V.14 mode and 1 in 4 for the +2.3% overspeed (extended signalling rate) mode.

To accommodate the requirements of V.14, the CMX868 Rx Mode Register can be set for 0, +1% or +2.3% overspeed operation in QAM modes. Missing Stop bits beyond those allowed by the selected overspeed option will set the Rx Framing Error flag bit of the Status Register.

## 6. C-BUS Interface and Software Description

This block provides for the transfer of data and control or status information between the CMX869's internal registers and the  $\mu$ C over the C-BUS serial bus. Each transaction consists of a single Register Address byte sent from the  $\mu$ C which may be followed by one or more data bytes sent from the  $\mu$ C to be written into one of the CMX869's Write Only Registers, or one or more bytes of data read out from one of the CMX869's Read Only Registers, as illustrated in Figure 8.

Data sent from the  $\mu$ C on the Command Data line is clocked into the CMX869 on the rising edge of the Serial Clock input. Reply Data sent from the CMX869 to the  $\mu$ C is valid when the Serial Clock is high. The CSN line must be held low during a data transfer and kept high between transfers. The C-BUS interface is compatible with most common  $\mu$ C serial interfaces and may also be easily implemented with general purpose  $\mu$ C I/O pins controlled by a simple software routine. Figure 13 gives detailed C-BUS timing requirements.

The following C-BUS addresses and registers are used by the CMX869:

General Reset Command (address only, no data).	Address \$01
General Control Register, 16-bit write only.	Address \$E0
Transmit Mode Register, 16-bit write-only.	Address \$E1
Receive Mode Register, 16-bit write-only.	Address \$E2
Transmit Data Register, 8 or 16-bit write only.	Address \$E3
Alternate Transmit Data Register, 8-bit write only.	Address \$E4
Receive Data Register, 8 or 16-bit read-only.	Address \$E5
Status Register, 16-bit read-only.	Address \$E6
Programming Register, 16-bit write-only.	Address \$E8
QAM Modem Command Register, 16-bit write-only.	Address \$EA
QAM Modem Status Register, 16-bit read-only.	Address \$EB

**Note:** The C-BUS addresses \$E7, \$E9, \$EC, \$ED, \$EE and \$EF are allocated for production testing and should not be accessed in normal operation.

### Interrupt Operation

The CMX869 will issue an interrupt, by taking the IRQN line low, when the IRQ bit 15 of the Status Register and the IRQ Enable bit 6 in the General Control Register are both set = 1. The IRQ bit operation is described in section 6.8.

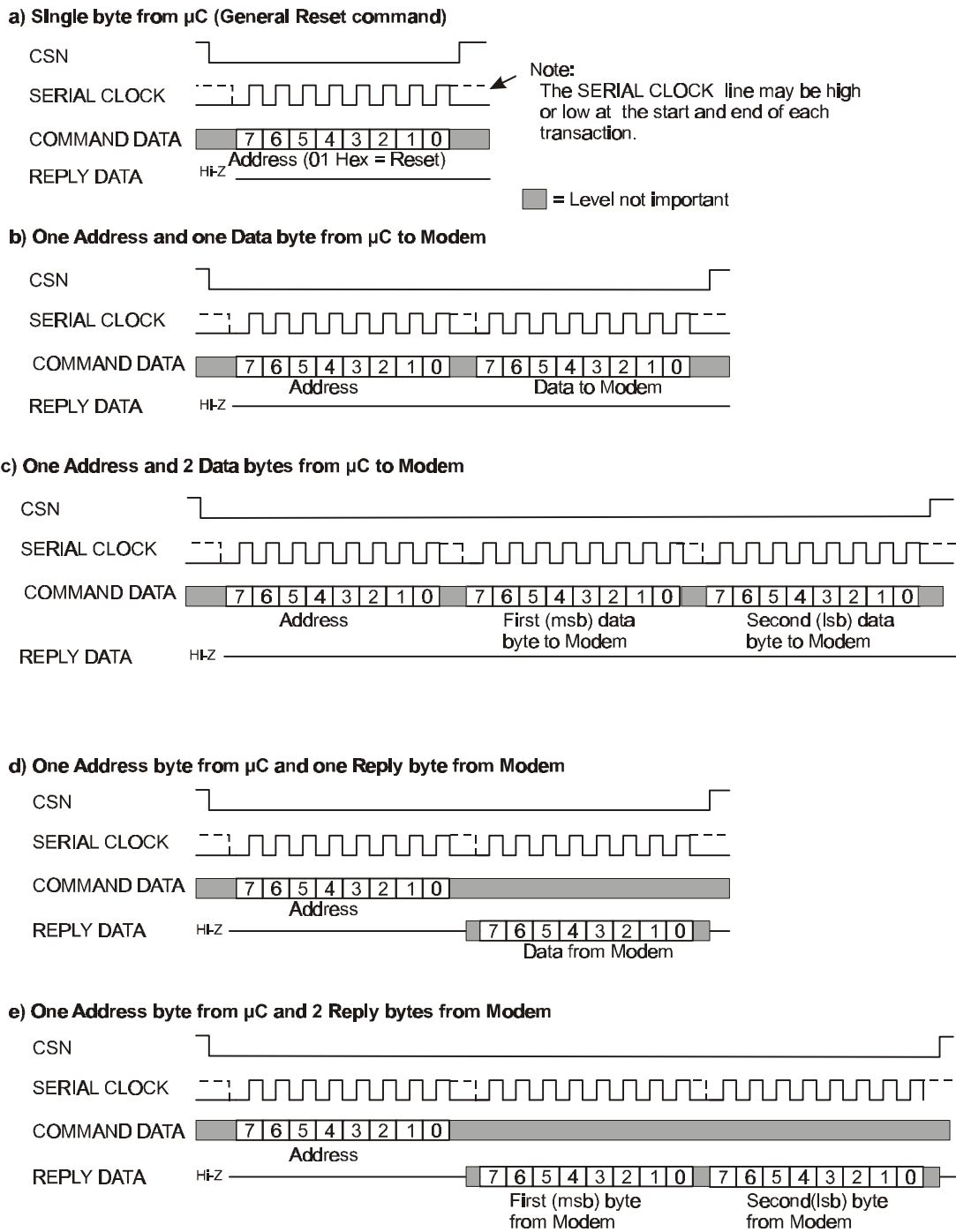

**Figure 8 C-BUS Transactions**

## 6.1 General Reset Command

### General Reset Command (no data) C-BUS address \$01

This command resets the device and clears all bits of the General Control, Transmit Mode and Receive Mode Registers and bits 15 and 13-0 of the Status Register. The General Reset command places the device into Powersave mode.

Whenever power is applied to the CMX869, a built in power-on-reset circuit ensures that the device powers up into the same state as follows a General Reset command. Nevertheless it is recommended that a General Reset command be sent to the device on power-up, after which the General Control Register should be set as required.

## 6.2 General Control Register

### General Control Register: 16-bit write-only. C-BUS address \$E0

This register controls general features of the CMX869 such as the Powersave and Loopback modes, the IRQ mask bits and the Relay Drive output.

All bits of this register are cleared to 0 by a General Reset command.

Bit:	15	14	13	12	11	10	9	8	7	6	5	4	3	2	1	0
	0	Hi Gain	0	0	LB	0	Rly drv	Pwr	Rst	Irqn en	IRQ Mask Bits					

#### General Control Register b15: Reserved, set to 0

#### General Control Register b14: Select high input gain

This bit selects the RXBN input pin and is used to increase the input stage gain.

B14 = 1	RXBN internally connected to RXAN
B14 = 0	RXBN open circuit

#### General Control Register b13,12: Reserved, set to 00

#### General Control Register b11: Analogue Loopback test mode

This bit controls the analogue loopback test mode. In loopback test mode both Transmit and Receive Mode Registers should be set to the same modem type, band and bit rate. The line interface relay must be open, as the test transmission that is fed back into the Rx path will appear at the Tx pins.

b11 = 1	Local analogue loopback mode enabled
b11 = 0	No loopback (normal modem operation)

#### General Control Register b10: Reserved, set to 0

**General Control Register b9: Relay Drive**

This bit directly controls the RDRVN output pin.

b9 = 1	RDRVN output pin pulled to Vss
b9 = 0	RDRVN output pin pulled to VDD

**General Control Register b8: Power-up**

This bit controls the internal power supply to most of the internal circuits, including the Xtal oscillator, internal clock synthesizer and VBIAS supply. Note that the General Reset command clears this bit, putting the device into Powersave mode.

b8 = 1	Device powered up normally
b8 = 0	Powersave mode (all circuits disabled, except the on-chip regulator, Ring Detect, RDRVN and C-BUS interface)

When power is first applied to the device, the following power-up procedure should be followed to ensure correct operation.

- i. (Power is applied to the device)
- ii. Issue a General Reset command.
- iii. Write to the General Control Register (address \$E0 setting both the Power-up bit (b8) and the reset bit (b7) to 1 – leave in this state for a minimum of about 20ms – this is required to ensure that the crystal oscillator, on-chip regulator and the V<sub>BIAS</sub> supply are all operating prior to running any transmit or receive functions
- iv. The device is now ready to be programmed as and when required. Examples:
  - A General Reset command could be issued to clear all the registers and therefore powersave the device.
  - The Reset bit in the General Control Register could be set to 0 as part of a routine to program all the relevant registers for setting up a particular operating mode.

When the device is switched from Powersave mode to normal operation by setting the Power-up bit to 1, the Reset bit should also be set to 1 and should be held at 1 for about 20ms while the on-chip regulator, crystal oscillator, clock synthesizer and V<sub>BIAS</sub> stabilise before starting to use the transmitter or receiver.

**General Control Register b7: Reset**

Setting this bit to 1 resets the CMX869's internal circuitry, clearing all bits of the Transmit and Receive Mode Registers and b13-0 of the Status Register.

b7 = 1	Internal circuitry in a reset condition.
b7 = 0	Normal operation

**General Control Register b6: IRQNEN (IRQN O/P Enable)**

Setting this bit to 1 enables the IRQN output pin.

b6 = 1	IRQN pin driven low (to Vss) if the IRQ bit of the Status Register = 1
b6 = 0	IRQN pin disabled (high impedance)

**General Control Register b5-0: IRQ Mask bits**

These bits affect the operation of the IRQ bit of the Status Register as described in section 6.8

### 6.3 Transmit Mode Register

#### Transmit Mode Register: 16-bit write-only. C-BUS address \$E1

This register controls the CMX869 transmit signal type and level. All bits of this register are cleared to 0 by a General Reset command or when b7 (Reset) of the General Control Register is 1.

Bit:	15	14	13	12	11	10	9	8	7	6	5	4	3	2	1	0
	Tx mode = modem				Tx level			Guard tone		2C	0	Start-stop / synch data		# data bits / synch data source		
	Tx mode = DTMF/Tones				Tx level			Reserved, set to 0000				DTMF or Tone select				
	Tx mode = Disabled				Set to 0000 0000 0000											

#### Tx Mode Register b15-12: Tx mode

These 4 bits select the transmit operating mode.

b15	b14	b13	b12	
1	1	1	x	Reserved, do not use
1	1	0	1	Reserved, do not use
1	1	0	0	V.22, V.22 bis, V.32, V.32 bis QAM modem
1	0	1	x	Reserved, do not use
1	0	0	1	V.21 300 bps FSK High band (Answering modem)
1	0	0	0	" Low band (Calling modem)
0	1	1	1	Bell 103 300 bps FSK High band (Answering modem)
0	1	1	0	" Low band (Calling modem)
0	1	0	1	V.23 FSK 1200 bps
0	1	0	0	" 75 bps
0	0	1	1	Bell 202 FSK 1200 bps
0	0	1	0	" 150 bps
0	0	0	1	DTMF / Tones
0	0	0	0	Transmitter disabled

#### Tx Mode Register b11-9: Tx level

These 3 bits set the gain of the Tx Level Control block.

b11	b10	b9	
1	1	1	0dB
1	1	0	-1.5dB
1	0	1	-3.0dB
1	0	0	-4.5dB
0	1	1	-6.0dB
0	1	0	-7.5dB
0	0	1	-9.0dB
0	0	0	-10.5dB

**Tx Mode Register b8-7: Tx Guard tone (V.22 bis mode)**

These 2 bits select the guard tone to be transmitted together with the highband (answer) V.22 bis signal. Ignored in all other modes.

b8	b7	
1	1	Tx 550Hz guard tone
1	0	Tx 1800Hz guard tone
0	x	No Tx guard tone

**Tx Mode Register b6: Tx Modem 2-Character mode**

Selects whether the Tx Data Register operates in 1 or 2 character mode.

B6	
1	2 character mode
0	1 character mode

**Tx Mode Register b5: Reserved, set to 0****Tx Mode Register b4-3: Tx Modem Data format**

These two bits select Special or Start-stop mode and the addition of a parity bit to transmitted characters in Start-stop mode.

b4	b3	
1	1	Special modes (see below)
1	0	Start-stop mode, no parity
0	1	Start-stop mode, even parity bit added to data bits
0	0	Start-stop mode, odd parity bit added to data bits

**Tx Mode Register b2-0: Tx Modem Data and Stop bits (Start-Stop modes)**

In Start-stop mode these three bits select the number of Tx data and stop bits.

b2	b1	b0	
1	1	1	8 data bits, 2 stop bits
1	1	0	8 data bits, 1 stop bit
1	0	1	7 data bits, 2 stop bits
1	0	0	7 data bits, 1 stop bit
0	1	1	6 data bits, 2 stop bits
0	1	0	6 data bits, 1 stop bit
0	0	1	5 data bits, 2 stop bits
0	0	0	5 data bits, 1 stop bit

**Tx Mode Register b2-0: Tx Modem Data source (Special modes)**

When b4-3 = 11 bits 2-0 select the source of the Transmitted data as below:

b2	b1	b0	
1	1	1	Synchronous , data bytes taken directly from the Tx Data Buffer
1	1	0	HDLC mode
1	0	x	Reserved, do not use.
0	1	1	Continuous 1s
0	1	0	Continuous 0s
0	0	1	Continuous alternating 1s and 0s
0	0	0	Reserved, do not use.

**Tx Mode Register b8-0: DTMF/Tones mode**

If DTMF/Tones transmit mode has been selected (Tx Mode Register b15-12 = 0001) then b8-5 should be set to 0000 and b4-0 will select a DTMF signal or a fixed tone or one of four programmed tones or tone pairs for transmission.

b4 = 0: Tx fixed tone or programmed tone pair

b3	b2	b1	b0	Tone frequency (Hz)	
0	0	0	0	No tone	
0	0	0	1	697	
0	0	1	0	770	
0	0	1	1	852	
0	1	0	0	941	
0	1	0	1	1209	
0	1	1	0	1336	
0	1	1	1	1477	
1	0	0	0	1633	
1	0	0	1	1300	(Calling tone)
1	0	1	0	2100	(Answer tone)
1	0	1	1	2225	(Answer tone)
1	1	0	0	Tone pair TA	Programmed Tx tone or tone pair, see 6.10
1	1	0	1	Tone pair TB	“
1	1	1	0	Tone pair TC	“
1	1	1	1	Tone pair TD	“

b4 = 1: Tx DTMF

b3	b2	b1	b0	Low frequency (Hz)	High frequency (Hz)	Keypad symbol
0	0	0	0	941	1633	D
0	0	0	1	697	1209	1
0	0	1	0	697	1336	2
0	0	1	1	697	1477	3
0	1	0	0	770	1209	4
0	1	0	1	770	1336	5
0	1	1	0	770	1477	6
0	1	1	1	852	1209	7
1	0	0	0	852	1336	8
1	0	0	1	852	1477	9
1	0	1	0	941	1336	0
1	0	1	1	941	1209	*
1	1	0	0	941	1477	#
1	1	0	1	697	1633	A
1	1	1	0	770	1633	B
1	1	1	1	852	1633	C



### 6.4 Receive Mode Register

#### Receive Mode Register: 16-bit write-only. C-BUS address \$E2

This register controls the CMX869 receive signal type and level.

All bits of this register are cleared to 0 by a General Reset command or when b7 (Reset) of the General Control Register is 1.

Bit:	15	14	13	12	11	10	9	8	7	6	5	4	3	2	1	0
	Rx mode = modem				Rx level			00	2C	Start-stop/Synch			No. of bits and parity			
	Rx mode = Tones detect				Rx level			DTMF/Tones/Call Progress select								
	Rx mode = Disabled				Set to 0000 0000 0000											

#### Rx Mode Register b15-12: Rx mode

These 4 bits select the receive operating mode.

b15	b14	b13	b12	
1	1	1	x	Reserved, do not use
1	1	0	1	Reserved, do not use
1	1	0	0	V.22, V.22 bis, V.32, V.32 bis QAM modem
1	0	1	x	Reserved, do not use
1	0	0	1	V.21 300 bps FSK High band (Calling modem)
1	0	0	0	" Low band (Answering modem)
0	1	1	1	Bell 103 300 bps FSK High band (Calling modem)
0	1	1	0	" Low band (Answering modem)
0	1	0	1	V.23 FSK 1200 bps
0	1	0	0	" 75 bps
0	0	1	1	Bell 202 FSK 1200 bps
0	0	1	0	" 150 bps
0	0	0	1	DTMF, Programmed tone pair, Answer Tone, Call Progress detect
0	0	0	0	Receiver disabled

#### Rx Mode Register b11-9: Rx level

These three bits set the internal gain of the Rx Gain Control block.

b11	b10	b9	
1	1	1	0dB
1	1	0	-1.5dB
1	0	1	-3.0dB
1	0	0	-4.5dB
0	1	1	-6.0dB
0	1	0	-7.5dB
0	0	1	-9.0dB
0	0	0	-10.5dB

**Rx Mode Register b8-7: Reserved, set to 00****Rx Mode Register b6: Rx Modem 2-Character mode**

Selects whether the Rx Data Register operates in 1 or 2 character mode

B6	
1	2 character mode
0	1 character mode

**Rx Mode Register b5-3: Rx Modem Data format**

These three bits select the Rx modem USART operating mode. The 1% and 2.3% overspeed options apply to QAM modes only.

b5	b4	b3	
1	1	1	Rx Special modes
1	1	0	Rx Start-stop mode, no overspeed
1	0	1	Rx Start-stop mode, +1% overspeed (1 in 8 missing Stop bits allowed)
1	0	0	Rx Start-stop mode, +2.3% overspeed (1 in 4 missing Stop bits allowed)
0	x	x	Rx USART function disabled

**Rx Mode Register b2-0: Rx Modem Data bits and Parity (Start-Stop modes)**

In Start-stop mode these three bits select the number of data bits (plus any parity bit) in each received character.

b2	b1	b0	
1	1	1	8 data bits + parity
1	1	0	8 data bits
1	0	1	7 data bits + parity
1	0	0	7 data bits
0	1	1	6 data bits + parity
0	1	0	6 data bits
0	0	1	5 data bits + parity
0	0	0	5 data bits

**Rx Mode Register b2-0: Rx Modem Data bits and Parity (Special modes)**

When b5-3 = 111 bits 2-0 select special receive modes as below:

b2	b1	b0	
1	1	1	Synchronous, received bits transferred directly to Rx Data Register
1	1	0	HDLC mode
1	0	X	Reserved, do not use.
0	x	x	Reserved, do not use.

**Rx Mode Register b2-0: Tones Detect mode**

In Tones Detect Mode (Rx Mode Register b15-12 = 0001) b8-3 should be set to 000000.

Bits 2-0 select the detector type.

b2	b1	b0	
1	0	0	Programmable Tone Pair Detect
0	1	1	Call Progress Detect
0	1	0	2100, 2225Hz Answer Tone Detect
0	0	1	DTMF Detect
0	0	0	Disabled

## 6.5 QAM Modem Command Register

### QAM Modem Command Register: 16-bit write-only. C-BUS address \$EA

Bit:	15	14	13	12	11	10	9	8	7	6	5	4	3	2	1	0
	0	0	0	0	0	0	0	0	0	0	Command			Protocol/Bit Rate		

The V.22, V.22 bis, V.32, V.32 bis QAM modem is controlled by writing the commands listed below to this register. B15-6 should all be cleared to 0. These commands will not take effect unless both Tx and Rx Mode Registers have both been set to QAM modem mode. This register should only be written to when b13 (Programming Flag bit) of the Status Register is 1.

Bit:	b5	b4	b3	b2	b1	b0	<b>Command</b>
	0	0	0	0	0	0	Stop modem
	F	0	1	Max bitrate			Initiate retrain
	F	1	0	Max bitrate			Start automodem in calling mode
	F	1	1	Max bitrate			Start automodem in answer mode
	1	0	0	Max bitrate			Initiate rate re-negotiation

F is the fast training flag bit:

In V.22 or V.22 bis modes: If F is set to 1 in a 'start automodem in answer mode' command the 2100Hz answer tone will not be transmitted. The F bit has no effect in other commands.

In V.32 or V.32 bis modes: If F is set to 1 a faster but less accurate echo cancellation training algorithm is used.

The 'Max bitrate' field defines the maximum bitrate that will be allowed by the modem during rate negotiations.

Bit:	Max bitrate			bps	Protocol
	b2	b1	b0		
	1	1	1	14400	V.32 bis
	1	1	0	12000	V.32 bis
	1	0	1	9600	V.32 / V.32 bis (with Trellis coding)
	1	0	0	9600	V.32 (no Trellis coding)
	0	1	1	7200	V.32 bis
	0	1	0	4800	V.32 / V.32 bis
	0	0	1	2400	V.22 bis
	0	0	0	1200	V.22 / V.22 bis

For most applications a connection can be established by ensuring that the Tx and Rx Mode registers have been set to QAM modem mode and that the Status Register b13 = 1 then writing a 'Start automodem (calling or answer mode)' command with the Max bitrate field set to 14400bps. The CMX869 will automatically attempt to execute the entire start-up procedure as described in V.32 bis, including the V.25 automatic answering sequence, receiver training and rate negotiation. Significant events occurring during this process will be reported in the QAM Modem Status Register. When a data connection has been established b3-0 of the QAM Modem Status Register will show a value of between 1000 and 1111, indicating the negotiated bit rate.

The CMX869 will automatically respond to V.32/V.32 bis retrain and rate re-negotiation requests from the distant modem; alternatively the 'Initiate retrain' and 'Initiate rate re-negotiation' commands can be used to initiate such requests. In both cases the progress of the retrain or rate re-negotiation will be reported in the QAM Modem Status Register.

## 6.6 Tx Data Register

### Tx Data Register: 8 or 16-bit write-only. C-BUS addresses \$E3 and \$E4

This register may be set to operate in 8 or 16-bit mode by b6 of the Tx Mode Register. This setting should not be changed once data transmission has started.

1-character mode (Tx Mode Register b6 = 0). C-Bus addresses \$E3 and \$E4

Bit:	7	6	5	4	3	2	1	0
Byte to be transmitted								

2-character mode (Tx Mode Register b6 = 1). C-Bus address \$E3 only

Bit:	15	14	13	12	11	10	9	8	7	6	5	4	3	2	1	0
First byte to be transmitted								Second byte to be transmitted								

This register should only be written to when the Tx Data Ready bit of the Status Register is set to 1.

In Synchronous and HDLC Tx data modes all 8 bits of a byte are transmitted, bit 0 of each byte being transmitted first.

In Tx Start-Stop modes the specified number of data bits will be taken from the byte in the Tx Data Register (b0 of the byte first). A Start bit, a Parity bit (if required) and Stop bit(s) will be added automatically.

C-BUS address \$E3 should normally be used, \$E4 has special functions depending on the setting of b6 of the Tx Mode Register:

If Tx Mode Register b6 = 0 (1-character mode) then address \$E4 is used to implement the V.14 overspeed transmission requirement in Start-Stop mode, see section 5.1.

If Tx Mode Register b6 = 1 (2-character mode) then a single character can be transmitted, say at the end of a message, by writing it as a single byte to address \$E4.

## 6.7 Rx Data Register

**Rx Data Register: 8 or 16-bit read-only. C-BUS address \$E5**

This register may be set to operate in 8 or 16-bit mode by b6 of the Rx Mode Register. This setting should not be changed once data reception has started.

1-character mode (Rx Mode Register b6 = 0).

Bit:	7	6	5	4	3	2	1	0
Received byte/character								

2-character mode (Rx Mode Register b6 = 1).

Bit:	15	14	13	12	11	10	9	8	7	6	5	4	3	2	1	0
First received byte/character								Second received byte/character								

In Synchronous and HDLC Rx data modes each byte contains 8 received data bits, b0 of the byte holding the earliest received bit, b7 the latest.

In Rx Start-Stop modes each byte contains the specified number of data bits from a received character, b0 of the byte holding the first received bit. Unused bits are set to 0.

## 6.8 Status Register

**Status Register: 16-bit read-only. C-BUS address \$E6**

Bits 13-0 of this register are cleared to 0 by a General Reset command or when b7 (Reset) of the General Control Register is 1.

Bit:	15	14	13	12	11	10	9	8	7	6	5	4	3	2	1	0
	IRQ	RD	PF	TxD	TxU	See below for uses of these bits										

The meanings of the Status Register bits 10-0 depend on the receive mode.

Status Register bits 15-11: All modes		IRQ Mask bit
b15	IRQ.	B6
b14	Set to 1 on Ring Detect	b5
b13	Programming Flag bit. See 6.10	b4
b12	Set to 1 on Tx data ready. Cleared by write to Tx Data Register	b3
b11	Set to 1 on Tx data underflow. Cleared by write to Tx Data Register	b3

Status Register bits 10-0: Rx Tones Detect modes		IRQ Mask bit
b10	Set to 1 when energy is detected in Call Progress band or when both programmable tones are detected	b2
b9	0	b1
b8	0	b1
b7	Set to 1 when 2100Hz answer tone or when the second programmable tone is detected	b1
b6	Set to 1 when 2225Hz answer tone or when the first programmable tone is detected	b0
b5	Set to 1 when DTMF code is detected	b0
b4	0	-
b3	Rx DTMF code b3, see table following	-
b2	Rx DTMF code b2	-
b1	Rx DTMF code b1	-
b0	Rx DTMF code b0	-

Status Register bits 10-7: Rx FSK Modem modes		IRQ Mask bit
b10	1 while energy is detected in Rx modem signal band	b2
b9	1 while '1010..' pattern is detected	b1
b8	1 while continuous 0s detected	b1
b7	1 while continuous 1s detected	b1

Status Register bits 10-7: QAM Modem (V.22, V.22 bis, V.32, V.32 bis) modes		IRQ Mask bit
b10	0	b2
b9	Set to 1 by modem event. Cleared by read of QAM modem Status Register	B1
b8	Set to 1 when V.14 'break' signal detected in Start-Stop mode	b1
b7	0	b1

Status Register bits 6-0: All Rx Modem modes		IRQ Mask bit
b6	Set to 1 on Rx data ready. Cleared by read from Rx Data Register	b0
b5	Set to 1 on Rx data overflow. Cleared by read from Rx Data Register	b0
b4	Set to 1 on Rx UART framing error or HDLC FCS error	-
b3	Start-Stop mode: set to 1 if Rx character has even parity (first character if in 2-character mode) HDLC mode: set to 1 when last byte (FCS) of HDLC packet is received	-
b2	Start-Stop mode: 1 if second Rx character has even parity (2-character mode)	-
b1	Set to 1 if Rx Data Register contains 2 characters (2-character mode)	-
b0	FSK frequency demodulator output (0 in QAM modes)	-

Notes: The IRQ Mask Bit column shows the corresponding IRQ Mask bits in the General Control Register. A 0 to 1 transition on any of the Status Register bits 14-5 will cause the IRQ bit 15 to be set to 1 if the corresponding IRQ Mask bit is 1. The IRQ bit is cleared by a read of the Status Register or a General Reset command or by setting b7 or b8 of the General Control Register to 1.

The IRQN output pin will be pulled low (to Vss) when the IRQ bit of the Status Register and the IRQNEN bit (b6) of the General Control Register are both set to 1.

The operation of the FSK data demodulator and pattern detector circuits within the CMX869 do not depend on the state of the Rx energy detect function.

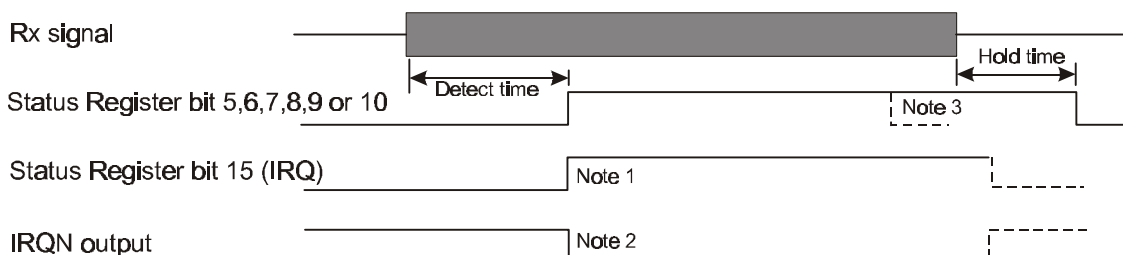

- Notes:
1. IRQ will go high only if appropriate IRQ Mask bit in General Control Register is set to 1. The IRQ bit is cleared by a read of the Status Register.
  2. IRQN o/p will go low when IRQ bit goes high, if IRQNEN bit of General Control Register is set to 1.
  3. In Rx Modem modes Status Register bits 5 and 6 are set to 1 by an Rx Data Ready or Rx Data Underflow event and cleared to 0 by a read of the Rx Data Register.

**Figure 9a Operation of Status Register bits 5-10**

Changes to Status Register bits caused by a change of Tx or Rx operating mode can take up to 150µs to take effect.

The Ring Detect bit (b14) continues to operate in Powersave mode or when the Reset bit (b7) of the General Control Register is 1. The Ring Detect bit follows the inverted state of the RDN input pin. An interrupt is only generated as a result of a negative transition on the RDN pin, if General Control Register bits 5 and 6 are set to 1.

In Rx FSK modem modes bit 0 will show the output of the frequency demodulator, updated at 8 times the nominal data rate.

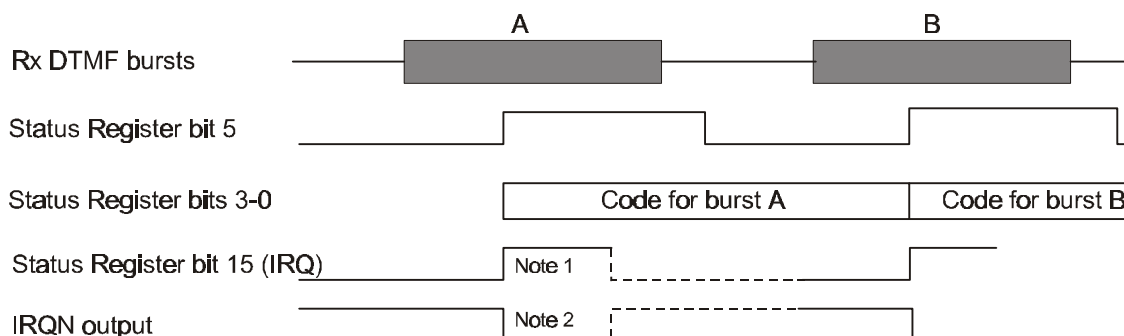

- Notes: 1. IRQ will go high only if the IRQ Mask bit 0 in the General Control Register is set to 1. The IRQ bit is cleared to 0 by a read of the Status Register.  
 2. IRQN o/p will go low when IRQ bit goes high, if IRQNEN bit of General Control Register is set to 1.

**Figure 9b Operation of Status Register in DTMF Rx Mode**

b3	b2	b1	b0	Low frequency (Hz)	High frequency (Hz)	Keypad symbol
0	0	0	0	941	1633	D
0	0	0	1	697	1209	1
0	0	1	0	697	1336	2
0	0	1	1	697	1477	3
0	1	0	0	770	1209	4
0	1	0	1	770	1336	5
0	1	1	0	770	1477	6
0	1	1	1	852	1209	7
1	0	0	0	852	1336	8
1	0	0	1	852	1477	9
1	0	1	0	941	1336	0
1	0	1	1	941	1209	*
1	1	0	0	941	1477	#
1	1	0	1	697	1633	A
1	1	1	0	770	1633	B
1	1	1	1	852	1633	C

**Received DTMF Code: b3-0 of Status Register**



## 6.9 QAM Modem Status Register

**QAM Modem Status Register: 16-bit read-only. C-BUS address \$EB**

This register should only be read from when b13 (Programming Flag bit) of the Status Register is 1.

Bit:	15	14	13	12	11	10	9	8	7	6	5	4	3	2	1	0
	Messages						0	0	0	SNR			Mode			

### QAM Modem Status Register b15-10: Messages

b15	b14	b13	b12	b11	b10	
1	1	1	Bit Rate			R5 received
1	1	0	Bit Rate			R4 received
1	0	1	Bit Rate			R3 received
1	0	0	Bit Rate			R2 received
0	1	1	Bit Rate			R1 received
0	1	0	1	1	1	Rate negotiation request detected
0	1	0	1	1	0	Retrain request detected
0	1	0	1	0	1	Emergency retrain started
0	1	0	1	0	0	Carrier lost
0	1	0	0	1	1	V.32 preamble detected
0	1	0	0	1	0	S1 detected
0	1	0	0	0	1	SB1 detected
0	1	0	0	0	0	USB1 detected
0	0	1	1	1	1	2100Hz detected
Other combinations of b15-10						unused

### Bit Rate field of Messages (see above)

b12	b11	b10	Bit Rate	Modem
1	1	1	14400	V.32 bis
1	1	0	12000	V.32 bis
1	0	1	9600	V.32 / V.32 bis (with Trellis coding)
1	0	0	9600	V.32 (no Trellis coding)
0	1	1	7200	V.32 bis
0	1	0	4800	V.32 / V.32 bis
0	0	1	2400	V.22 bis
0	0	0	1200	V.22 / V.22 bis

### QAM Modem Status Register b9-7: Unused (000)

**QAM Modem Status Register b6-4: Signal to Noise**

b6	b5	b4	
1	1	1	Very good; could increase rate or retrain
1	1	0	Good
1	0	1	Normal
1	0	0	Poor
0	1	1	Bad; receiver will have a high error rate
0	1	0	Really bad; should decrease data rate or retrain
0	0	1	Unused
0	0	0	SNR not yet determined

**QAM Modem Status Register b3-0: Operating Mode**

b3	b2	b1	b0	
1	1	1	1	14400 bps V.32 bis
1	1	1	0	12000 bps V.32 bis
1	1	0	1	9600 bps V.32 / V.32 bis (with Trellis coding)
1	1	0	0	9600 bps V.32 (no Trellis coding)
1	0	1	1	7200 bps V.32 bis
1	0	1	0	4800 bps V.32 / V.32 bis
1	0	0	1	2400 bps V.22 bis
1	0	0	0	1200 bps V.22 / V.22 bis
0	1	1	1	Unused
0	1	1	0	Unused
0	1	0	1	Unused
0	1	0	0	Training / Rate negotiation
0	0	1	1	Transmitting 2100Hz answer tone
0	0	1	0	Tx silence, Rx idle
0	0	0	1	Tx idle, Rx waiting
0	0	0	0	Idle

An update to the Messages status (b15 – b10) or any change in SNR or Mode status (b6 – b0) will cause b9 of the main Status Register to be set to 1.

## 6.10 Programming Register

### Programming Register : 16-bit write-only. C-BUS address \$E8

This register is used to program the transmit and receive programmed tone pairs by writing appropriate values to RAM locations within the CMX869. Note that these RAM locations are cleared by Powersave or Reset.

The Programming Register should only be written to when the Programming Flag bit (b13) of the Status Register is 1. The act of writing to the Programming Register clears the Programming Flag bit. When the programming action has been completed (normally within 150µs) the CMX869 will set the bit back to 1.

When programming Transmit or Receive Tone Pairs, do not change the Transmit or Receive Mode Registers until programming is complete and the Programming Flag bit has returned to 1.

### Transmit Tone Pair Programming

4 transmit tone pairs (TA to TD) can be programmed.

The frequency (max 3.4kHz) and level must be entered for each tone to be used.

Single tones are programmed by setting both level and frequency values to zero for one of the pair.

Programming is done by writing a sequence of seventeen 16-bit words to the Programming Register. The first word should be 32768 (8000 hex), the following 16-bit words set the frequencies and levels and are in the range 0 to 16383 (0-3FFF hex)

Word	Tone Pair	Value written
1		32768
2	TA	Tone 1 frequency
3	TA	Tone 1 level
4	TA	Tone 2 frequency
5	TA	Tone 2 level
6	TB	Tone 1 frequency
7	TB	Tone 1 level
---	---	-----
---	---	-----
16	TD	Tone 2 frequency
17	TD	Tone 2 level

The Frequency values to be entered are calculated from the formula:

$$\text{Value to be entered} = \text{desired frequency (Hz)} * 3.414$$

i.e. for 1kHz the value to be entered is 3414 (or 0D56 in Hex).

The Level values to be entered are calculated from the formula:

$$\text{Value to be entered} = \text{desired } V_{rms} * 93780 / AV_{DD}$$

i.e. for 0.5V<sub>rms</sub> at AV<sub>DD</sub> = 3.3V, the value to be entered is 14209 (3781 in Hex)

Programming a notone pair is done by writing zero to all four tone pair words. On power-up or after a reset, the tone pairs TA-TC are set to notone, and TD is set to generate 2130Hz + 2750Hz at approximately -18dBm (100mV<sub>rms</sub>) each. Unprogrammed tone pairs retain their previous values.

Allowance should be made for the transmit signal filtering in the CMX869 which attenuates the output signal for frequencies above 2kHz, by 0.25dB at 2.5kHz, by 1dB at 3kHz, and by 2.2dB at 3.4kHz.

### Receive Tone Pair Programming

The Programmable Tone Pair Detector is implemented as shown in Figure 10a. The filters are 4<sup>th</sup> order IIR sections. The frequency detectors measure the time taken for a programmable number of complete input signal cycles and compare this time against programmable upper and lower limits.

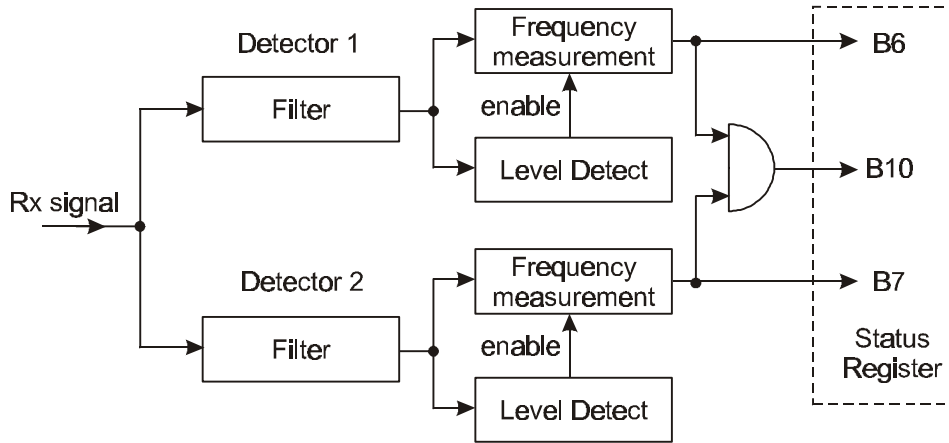

Figure 10a Programmable Tone Pair Detector

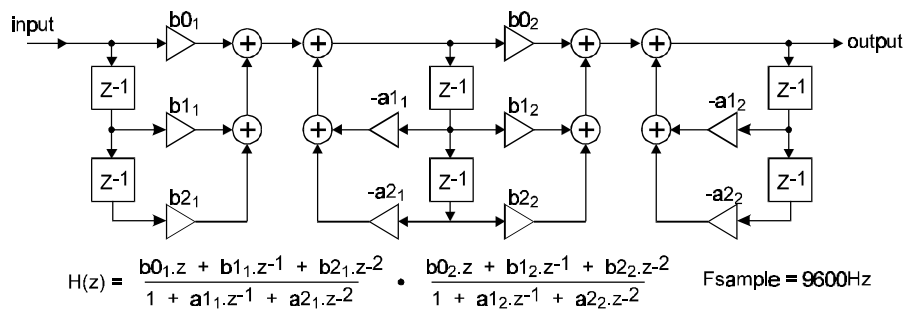

Figure 10b Filter Implementation

Programming is done by writing a sequence of twenty-seven 16-bit words to the Programming Register. The first word should be 32769 (8001 hex), the following twenty-six 16-bit words set the frequencies and levels and are in the range 0 to 32767 (0000-7FFF hex).

Word	Value written	Word	Value written
1	32769	15	Filter #2 coefficient b <sub>21</sub>
2	Filter #1 coefficient b <sub>21</sub>	16	Filter #2 coefficient b <sub>11</sub>
3	Filter #1 coefficient b <sub>11</sub>	17	Filter #2 coefficient b <sub>01</sub>
4	Filter #1 coefficient b <sub>01</sub>	18	Filter #2 coefficient a <sub>21</sub>
5	Filter #1 coefficient a <sub>21</sub>	19	Filter #2 coefficient a <sub>11</sub>
6	Filter #1 coefficient a <sub>11</sub>	20	Filter #2 coefficient b <sub>22</sub>
7	Filter #1 coefficient b <sub>22</sub>	21	Filter #2 coefficient b <sub>12</sub>
8	Filter #1 coefficient b <sub>12</sub>	22	Filter #2 coefficient b <sub>02</sub>
9	Filter #1 coefficient b <sub>02</sub>	23	Filter #2 coefficient a <sub>22</sub>
10	Filter #1 coefficient a <sub>22</sub>		

11	Filter #1 coefficient $a_{12}$	24	Filter #2 coefficient $a_{12}$
12	Freq measurement #1 ncycles	25	Freq measurement #2 ncycles
13	Freq measurement #1 mintime	26	Freq measurement #2 mintime
14	Freq measurement #1 maxtime	27	Freq measurement #2 maxtime

The coefficients are entered as 15-bit signed (two's complement) integer values (the most significant bit of the 16-bit word entered should be zero) calculated as  $8192 * \text{coefficient value}$  from the user's filter design program (i.e. this allows for filter design values of -1.9999 to +1.9999).

The design of the IIR filters should make allowance for the fixed receive signal filtering in the CMX869 which has a low pass characteristic above 1.5kHz, of 0.4dB at 2kHz, 1.2dB at 2.5kHz, 2.6dB at 3kHz and 4.1dB at 3.4kHz.

'ncycles' is the number of signal cycles for the frequency measurement.

'mintime' is the smallest acceptable time for ncycles of the input signal expressed as the number of 9.6kHz timer clocks. i.e.  $\text{'mintime'} = 9600 * \text{ncycles} / \text{high frequency limit}$

'maxtime' is the highest acceptable time for ncycles of the input signal expressed as the number of 9.6kHz timer clocks. i.e.  $\text{'maxtime'} = 9600 * \text{ncycles} / \text{low frequency limit}$

The level detectors include hysteresis. The threshold levels - measured at the 2 or 4-wire line with unity gain filters, using the line interface circuits described in section 4.3, 1.0 dB line coupling transformer loss and with the Rx Gain Control block set to 0dB - are nominally:

'Off' to 'On'	-42.0dBm
'On' to 'Off'	-44.5dBm

Note that if any changes are made to the programmed values while the CMX869 is running in Programmed Tone Detect mode they will not take effect until the CMX869 is next switched into Programmed Tone Detect mode.

On power-up or after a reset, the programmable tone pair detector is set to act as a simple 2130Hz + 2750Hz detector.

## 7. Application Notes

TBD

## 8. Performance Specification

### 8.1 Electrical Performance

#### 8.1.1 Absolute Maximum Ratings

Exceeding these maximum ratings can result in damage to the device.

	Min.	Max.	Units
Supply ( $AV_{DD} - AV_{SS}$ ) or ( $DV_{DD} - DV_{SS}$ )	-0.3	+4.0	V
Voltage on any pin (except $V_{DEC}$ ) to $AV_{SS}$ or $DV_{SS}$	-0.3	$V_{DD} + 0.3$	V
Voltage between $AV_{SS}$ and $DV_{SS}$	-50	+50	mV
Voltage between $AV_{DD}$ and $DV_{DD}$	-300	+300	mV
Current into or out of $AV_{SS}$ , $DV_{SS}$ , $AV_{DD}$ or $DV_{DD}$ pins	-50	+50	mA
Current into RDRVN pin (RDRVN pin low)		+50	mA
Current into or out of any other pin	-20	+20	mA

<b>D2 Package</b>	Min.	Max.	Units
Total Allowable Power Dissipation at $T_{amb} = 25^{\circ}\text{C}$		1000	mW
... Derating		13	mW/ $^{\circ}\text{C}$
Storage Temperature	-55	+125	$^{\circ}\text{C}$
Operating Temperature	-40	+85	$^{\circ}\text{C}$

<b>E2 Package</b>	Min.	Max.	Units
Total Allowable Power Dissipation at $T_{amb} = 25^{\circ}\text{C}$		400	mW
... Derating		5.3	mW/ $^{\circ}\text{C}$
Storage Temperature	-55	+125	$^{\circ}\text{C}$
Operating Temperature	-40	+85	$^{\circ}\text{C}$

<b>P4 Package</b>	Min.	Max.	Units
Total Allowable Power Dissipation at $T_{amb} = 25^{\circ}\text{C}$		1000	mW
... Derating		13	mW/ $^{\circ}\text{C}$
Storage Temperature	-55	+125	$^{\circ}\text{C}$
Operating Temperature	-40	+85	$^{\circ}\text{C}$

#### 8.1.2 Operating Limits

Correct operation of the device outside these limits is not implied.

	Notes	Min.	Max.	Units
Supply ( $AV_{DD} - AV_{SS}$ ) and ( $DV_{DD} - DV_{SS}$ )		3.0	3.6	V
Supply rise time (10% to 90%)			25	ms
Operating Temperature		-40	+85	$^{\circ}\text{C}$

### 8.1.3 Operating Characteristics

For the following conditions unless otherwise specified:

$V_{DD} = AV_{DD} = DV_{DD} = 3.0V$  to  $3.6V$  at  $T_{amb} = -40$  to  $+85^{\circ}C$ ;  $V_{SS} = AV_{SS} = DV_{SS}$ ;

Xtal Frequency =  $6.144MHz \pm 0.005\%$  (50ppm);

0dBm corresponds to 775mVrms. General Control Register bit 14 = 0 (High Rx Gain turned off).

**NOTE: All dBm limits TBD.**

DC Parameters	Notes	Min.	Typ.	Max.	Units
$I_{DD}$ (Powersave mode)	1, 2	-	6	TBD	$\mu A$
(Reset but not powersave)	1, 3	-	2	TBD	mA
(Running, $AV_{DD} = DV_{DD} = 3.3V$ )	1	-	12	TBD	mA
Logic '1' Input Level	4	70%	-	-	$DV_{DD}$
Logic '0' Input Level	4	-	-	30%	$DV_{DD}$
Logic Input Leakage Current ( $V_{in} = 0$ to $DV_{DD}$ ), (excluding XTAL/CLOCK input)		-1.0	-	+1.0	$\mu A$
Output Logic '1' Level ( $I_{OH} = 0.6$ mA)		80%	-	-	$V_{DD}$
Output Logic '0' Level ( $I_{OL} = -1.0$ mA)		-	-	+0.4	V
IRQN O/P 'Off' State Current ( $V_{out} = V_{DD}$ )		-1.0	-	+1.0	$\mu A$
RDN pin Schmitt trigger input high-going threshold ( $V_{thi}$ ) (see Figure 11)		$0.56 V_{DD}$	-	$0.56 V_{DD}$	V
RDN pin Schmitt trigger input low-going threshold ( $V_{tlo}$ ) (see Figure 11)		$0.44 V_{DD}$	-	$0.44 V_{DD}$	V
RDRVN 'ON' resistance to $DV_{SS}$ ( $DV_{DD} = 3.3V$ )		-	50	70	$\Omega$
RDRVN 'OFF' resistance to $DV_{DD}$ ( $DV_{DD} = 3.3V$ )		-	1170	3000	$\Omega$

- Notes:
1. At  $25^{\circ}C$ , not including any current drawn from the CMX869 pins by external circuitry other than X1, C5 and C6.
  2. All logic inputs at  $DV_{SS}$  except CSN input which is at  $DV_{DD}$ .
  3. General Control Register b8 and b7 both set to 1.
  4. Excluding RDN pin.

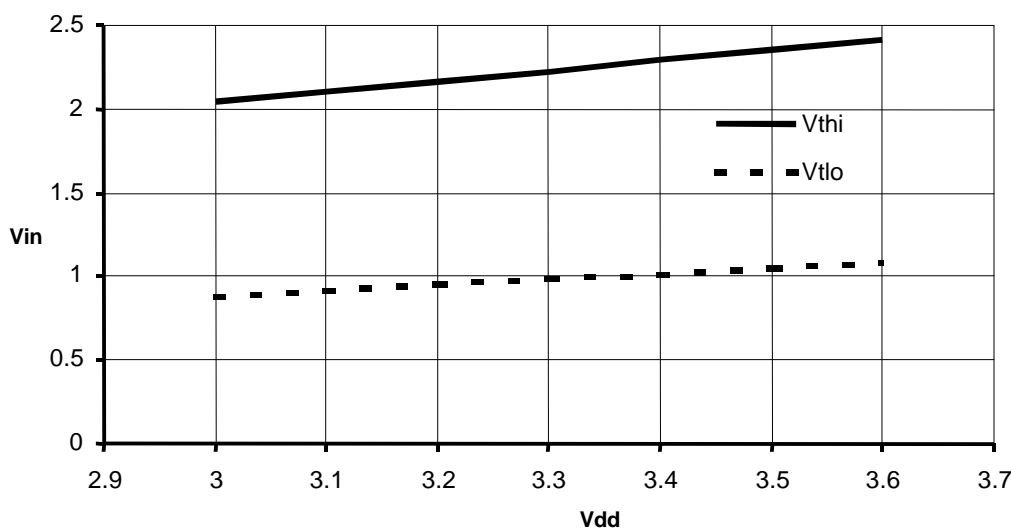

Figure 11 Typical Schmitt Trigger Input Voltage Thresholds vs.  $V_{DD}$



<b>XTAL/CLOCK Input</b> (timings for an external clock input)	<b>Notes</b>	<b>Min.</b>	<b>Typ.</b>	<b>Max.</b>	<b>Units</b>
'High' Pulse Width		60	-	-	ns
'Low' Pulse Width		60	-	-	ns

<b>Transmit Output Level</b>	<b>Notes</b>	<b>Min.</b>	<b>Typ.</b>	<b>Max.</b>	<b>Units</b>
Modem and Single Tone modes	5	-1.5	-0.5	0.5	dBm
DTMF mode, Low Group tones	5	0.5	1.5	2.5	dBm
DTMF: level of High Group tones wrt Low Group	5	+1.0	+2.0	+3.0	dB
Tx output buffer gain control accuracy	5	-0.25	-	+0.25	dB

Notes: 5. Measured between TXA and TXAN pins with Tx Level Control gain set to 0dB, 1.2kΩ load between TXA and TXAN, at AV<sub>DD</sub> = 3.3V (levels are proportional to AV<sub>DD</sub> - see section 4.3). Level measurements for all modem modes are performed with random transmitted data and without any guard tone. 0dBm = 775mVrms.

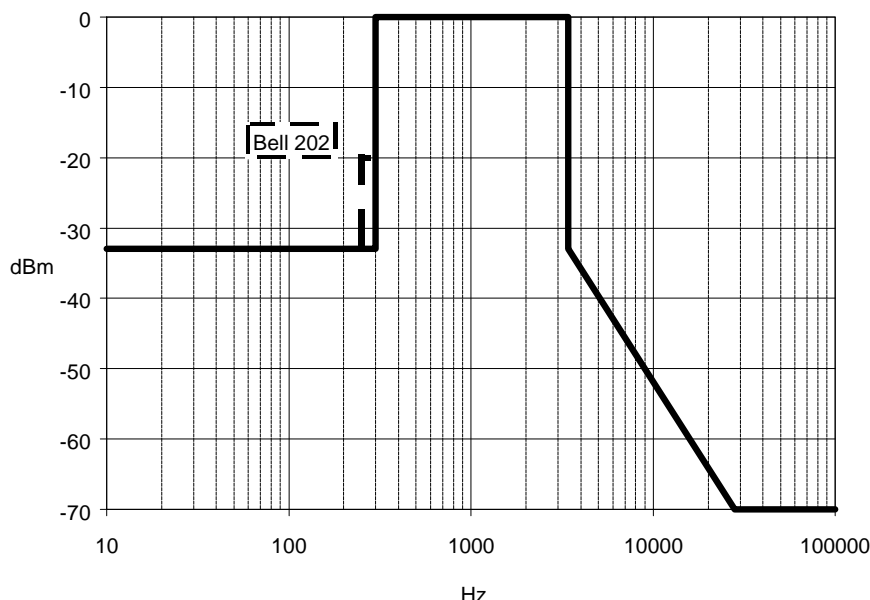

**Figure 12 Maximum Out of Band Tx Line Energy Limits (see note 6)**

Notes: 6. Measured on the 2 or 4-wire line using the line interface circuits described in section 4.3 with the Tx line signal level set to -10dBm for any modem mode or single tones, -6dBm and -8dBm for DTMF tones. Excludes any distortion due to external components such as the line coupling transformer.

<b>Rx Modem Energy Detector (FSK modes)</b>	<b>Notes</b>	<b>Min.</b>	<b>Typ.</b>	<b>Max.</b>	<b>Units</b>
Detect threshold ('Off' to 'On')	7, 8	-	-	-43.0	dBm
Undetect threshold ('On' to 'Off')	7, 8	-48.0	-	-	dBm
Hysteresis	7, 8	2.0	-	-	dB
<b>Detect ('Off' to 'On') response time</b>					
300 and 1200 baud FSK modes	7, 8	8.0	-	30.0	ms
150 and 75 baud FSK modes	7, 8	16.0	-	60.0	ms
<b>Undetect ('On' to 'Off') response time</b>					
300 and 1200 baud FSK modes	7, 8	10.0	-	40.0	ms
150 and 75 baud FSK modes	7, 8	20.0	-	80.0	ms
<b>Rx Answer Tone Detectors</b>					
Detect threshold ('Off' to 'On')	7,9	-	-	-43.0	dBm
Undetect threshold ('On' to 'Off')	7,9	-48.0	-	-	dBm
Detect ('Off' to 'On') response time	7,9	30.0	33.0	45.0	ms
Undetect ('On' to 'Off') response time	7,9	7.0	18.0	25.0	ms
<b>2100Hz detector</b>					
'Will detect' frequency		2050	-	2160	Hz
'Will not detect' frequency		-	-	2000	Hz
<b>2225Hz detector</b>					
'Will detect' frequency		2160	-	2285	Hz
'Will not detect' frequency		2335	-	-	Hz
<b>Rx Call Progress Energy Detector</b>					
Bandwidth (-3dB points) See Figure 6		275	-	665	Hz
Detect threshold ('Off' to 'On')	7,10	-	-	-37.0	dBm
Undetect threshold ('On' to 'Off')	7,10	-42.0	-	-	dBm
Detect ('Off' to 'On') response time	7,10	30.0	36.0	45.0	ms
Undetect ('On' to 'Off') response time	7,10	6.0	8.0	50.0	ms

- Notes: 7. Rx 2 or 4-wire line signal level with Rx Gain Control block set to 0dB and external components of section 4.3 set so that level at RXAFB pin is 3.6dB below the line signal level. Measured at  $A_{V_{DD}} = 3.3V$ .
8. Thresholds and times measured with continuous binary '1' for all FSK modes. Times measured with signal switched between off and -33dBm
9. 'Typical' value refers to 2100Hz or 2225Hz signal switched between off and -33dBm. Times measured wrt. received line signal.
10. 'Typical' values refers to 400Hz signal switched between off and -33dBm.

<b>DTMF Decoder</b>	<b>Notes</b>	<b>Min.</b>	<b>Typ.</b>	<b>Max.</b>	<b>Unit</b>
Valid input signal levels (each tone of composite signal)	7	-30.0	-	0.0	dBm
Not decode level (either tone of composite signal)	7	-	-	-36.0	dBm
Twist = High Tone/Low Tone		-10.0	-	6.0	dB
Frequency Detect Bandwidth		±1.8	-	-	%
Frequency Not Detect Bandwidth		-	-	±3.5	%
Max level of low frequency noise (i.e dial tone)					
Interfering signal frequency <= 550Hz	11	-	-	0.0	dB
Interfering signal frequency <= 450Hz	11	-	-	10.0	dB
Interfering signal frequency <= 200Hz	11	-	-	20.0	dB
Max. noise level wrt. signal	11, 12	-	-	-10.0	dB
DTMF detect response time		-	-	40.0	ms
DTMF de-response time		-	-	30.0	ms
Status Register b5 high time		14.0	-	-	ms
'Will Detect' DTMF signal duration		40.0	-	-	ms
'Will Not Detect' DTMF signal duration		-	25.0	-	ms
Pause length detected		30.0	-	-	ms
Pause length ignored		-	-	15.0	ms

Notes: 11. Referenced to DTMF tone of lower amplitude.  
12 Flat Gaussian Noise in 300-3400Hz band.

<b>Receive Input Amplifier</b>	<b>Notes</b>	<b>Min.</b>	<b>Typ.</b>	<b>Max.</b>	<b>Units</b>
Input impedance (at 100Hz)		10.0			Mohm
Open loop gain (at 100Hz)			10000		V/V
Rx Gain Control Block accuracy		-0.25		+0.25	dB

C-BUS Timings (See Figure 13)		Notes	Min.	Typ.	Max.	Units
$t_{CSE}$	CSN-Enable to Clock-High time		100	-	-	ns
$t_{CSH}$	Last Clock-High to CSN-High time		100	-	-	ns
$t_{LOZ}$	Clock-Low to Reply Output enable time		0.0	-	-	ns
$t_{HIZ}$	CSN-High to Reply Output 3-state time		-	-	1.0	$\mu$ s
$t_{CSOFF}$	CSN-High Time between transactions		1.0	-	-	$\mu$ s
$t_{NXT}$	Inter-Byte Time		200	-	-	ns
$t_{CK}$	Clock-Cycle time		200	-	-	ns
$t_{CH}$	Serial Clock-High time		100	-	-	ns
$t_{CL}$	Serial Clock-Low time		100	-	-	ns
$t_{CDS}$	Command Data Set-Up time		75.0	-	-	ns
$t_{CDH}$	Command Data Hold time		25.0	-	-	ns
$t_{RDS}$	Reply Data Set-Up time		50.0	-	-	ns
$t_{RDH}$	Reply Data Hold time		0.0	-	-	ns

Maximum 30pF load on each C-BUS interface line.

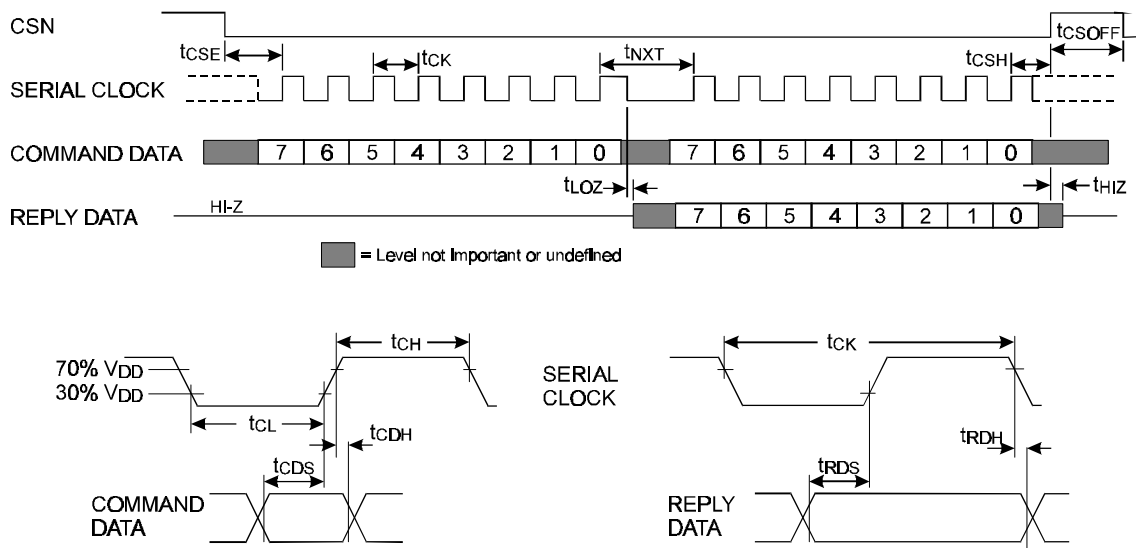

Figure 13 C-BUS Timing

8.2 Packaging

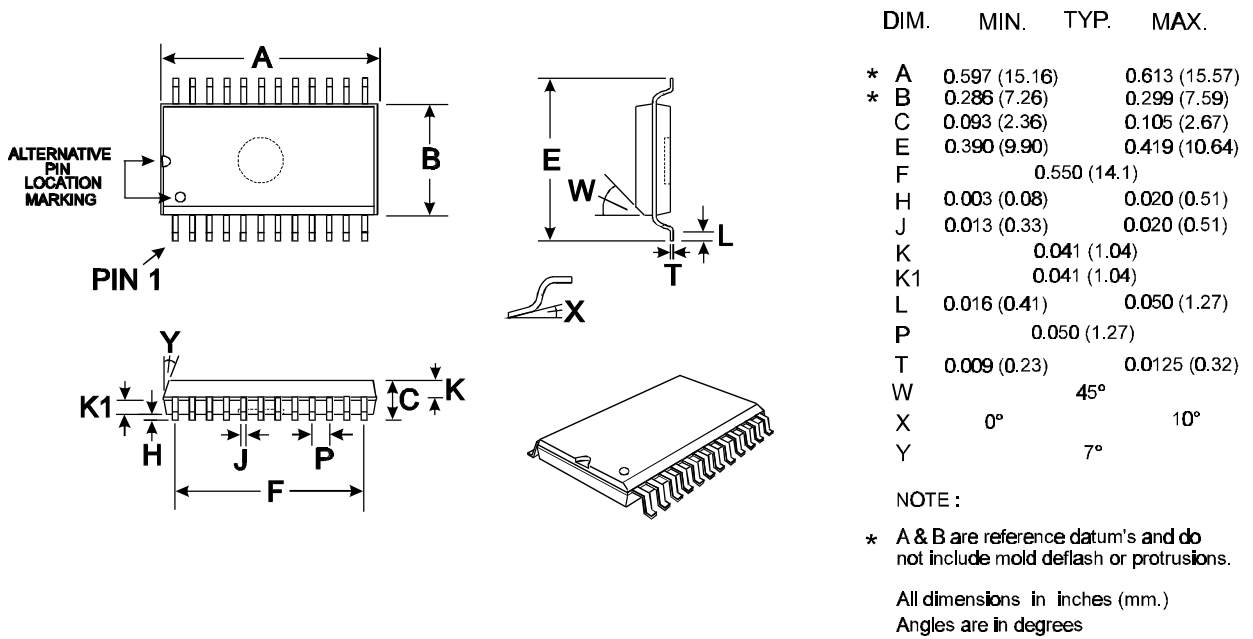

Figure 14a 24-pin SOIC (D2) Mechanical Outline: Order as part no. CMX869D2

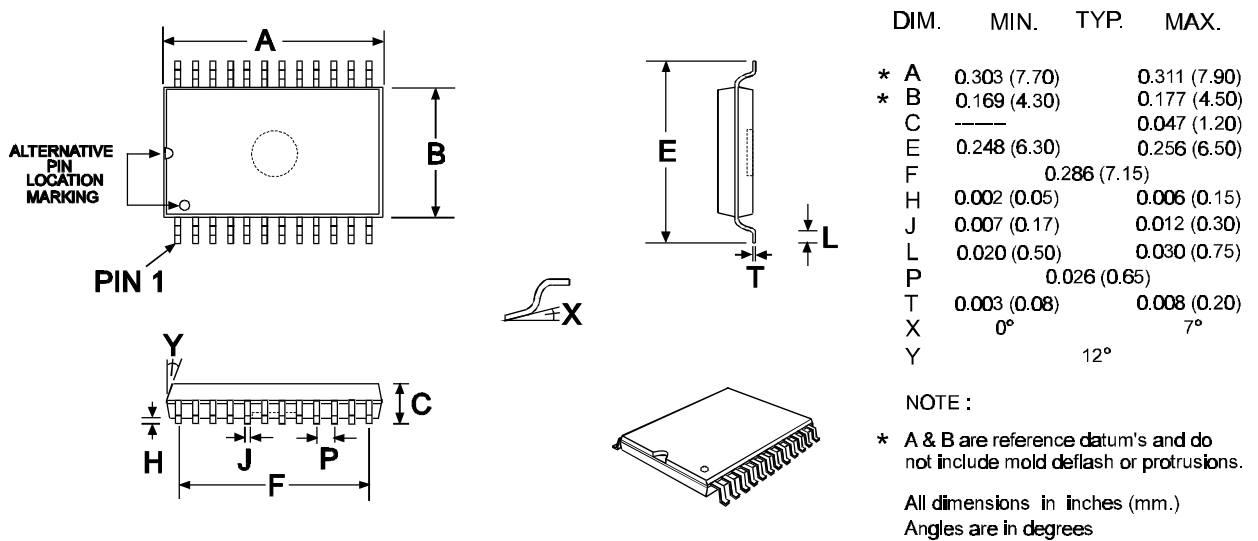

Figure 14b 24-pin TSSOP (E2) Mechanical Outline: Order as part no. CMX869E2

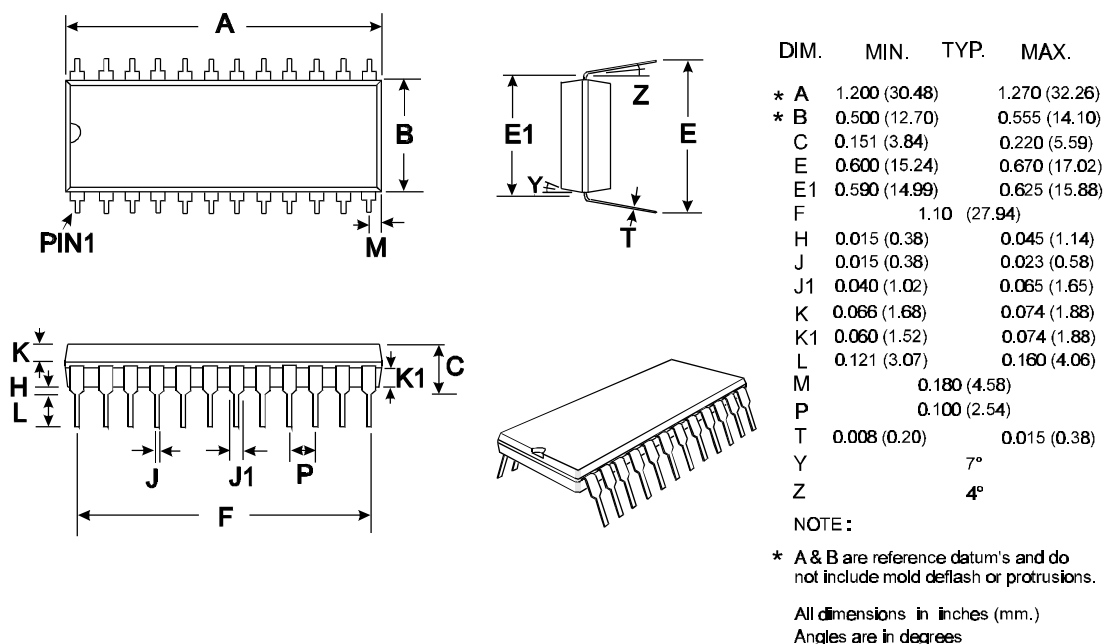

Figure 14c 24-pin DIL (P4) Mechanical Outline: Order as part no. CMX869P4

Handling precautions: This product includes input protection, however, precautions should be taken to prevent device damage from electro-static discharge. CML does not assume any responsibility for the use of any circuitry described. No IPR or circuit patent licences are implied. CML reserves the right at any time without notice to change the said circuitry and this product specification. CML has a policy of testing every product shipped using calibrated test equipment to ensure compliance with this product specification. Specific testing of all circuit parameters is not necessarily performed.

[www.cmlmicro.com](http://www.cmlmicro.com)

For FAQs see: [www.cmlmicro.com/products/faqs/](http://www.cmlmicro.com/products/faqs/)

For a full data sheet listing see: [www.cmlmicro.com/products/datasheets/download.htm](http://www.cmlmicro.com/products/datasheets/download.htm)

For detailed application notes: [www.cmlmicro.com/products/applications/](http://www.cmlmicro.com/products/applications/)

 <p>CML Microcircuits (UK) Ltd COMMUNICATION SEMICONDUCTORS</p>	 <p>CML Microcircuits (USA) Inc. COMMUNICATION SEMICONDUCTORS</p>	 <p>CML Microcircuits (Singapore) Pte Ltd COMMUNICATION SEMICONDUCTORS</p>	
Oval Park, Langford, Maldon, Essex, CM9 6WG - England.  Tel: +44 (0)1621 875500 Fax: +44 (0)1621 875600  Sales: <a href="mailto:sales@cmlmicro.com">sales@cmlmicro.com</a>  Technical Support: <a href="mailto:techsupport@cmlmicro.com">techsupport@cmlmicro.com</a>	4800 Bethania Station Road, Winston-Salem, NC 27105 - USA.  Tel: +1 336 744 5050, 800 638 5577 Fax: +1 336 744 5054  Sales: <a href="mailto:us.sales@cmlmicro.com">us.sales@cmlmicro.com</a>  Technical Support: <a href="mailto:us.techsupport@cmlmicro.com">us.techsupport@cmlmicro.com</a>	No 2 Kallang Pudding Road, #09 to 05/06 Mactech Industrial Building, Singapore 349307  Tel: +65 6745 0426 Fax: +65 6745 2917  Sales: <a href="mailto:sg.sales@cmlmicro.com">sg.sales@cmlmicro.com</a>  Technical Support: <a href="mailto:sg.techsupport@cmlmicro.com">sg.techsupport@cmlmicro.com</a>	No. 218, Tian Mu Road West, Tower 1, Unit 1008, Shanghai Kerry Everbright City, Zhabei, Shanghai 200070, China.  Tel: +86 21 6317 4107 +86 21 6317 8916 Fax: +86 21 6317 0243  Sales: <a href="mailto:cn.sales@cmlmicro.com.cn">cn.sales@cmlmicro.com.cn</a>  Technical Support: <a href="mailto:sg.techsupport@cmlmicro.com">sg.techsupport@cmlmicro.com</a>